

**DRAINAGE REPORT
FOR THE**

DEMONTÉ BRANCH DRAIN

TOWN OF TECUMSEH



(FINAL – COUNCIL CONSIDERATION)
5 AUGUST, 2022
MARK D. HERNANDEZ, P.ENG
FILE No. 17-5617
Tecumseh File No. E09EI(33)



Mayor and Council
The Corporation of the Town of Tecumseh
917 Lesperance Road
Tecumseh, Ontario
N8N 1W9

**Drainage Report for the
DEMONTÉ BRANCH DRAIN
Town of Tecumseh**

Mayor and Council:

Instructions

The Municipality received a petition from the Road Authority for a legal outlet for Webster Drive dated 9 January 2017. Currently, there is an existing private drainage system on private lands which provides inadequate drainage. As the petition is signed by the Road Authority, it is valid under Section 4(1)(c) and the Municipality has authority to proceed under the Act. Council accepted the valid petition under Section 4 of the Drainage Act and on 14 March 2017 appointed Dillon Consulting Limited to prepare a report.

Area Requiring Drainage

The Demonté Branch Drain consists of an open channel commencing at Station 0+184. The drain flows easterly along the north side of a private road and outlets into the 8th Concession Drain North. We have made an examination of the area requiring drainage along Webster Drive. The area requiring drainage encompasses the lands fronting Webster Drive. The lands within the watershed primarily consist of industrial lots. The area requiring drainage is approximately 15.07 acres (11.69 hectares) in the Town of Tecumseh.

Drain History

The recent history of Engineers' reports for the Demonté Branch Drain follows:

- **3 February 2000 by Lou Zarlenga, P.Eng.:** The report established the Demonté Branch Drain as a municipal drain. The recommended work included the repair and improvement of the open drain portion including improvements to existing culverts and enclosing 65 metres with 600 mm diameter H.D.P.E. pipe at the upstream end of the drain.

3200 Deziel Drive
Suite 608
Windsor, Ontario
Canada
N8W 5K8
Telephone
519.948.5000
Fax
519.948.5054

On-Site Meeting

We conducted an on-site meeting on 2nd May 2017. A record of the meeting is provided in Schedule 'A', which is appended hereto.

Survey

Our survey and examination of the Demonte Branch Drain and surrounding area was carried out in June 2017. The survey comprised the recording of topographic data and examining the existing drain for available depth necessary to provide sufficient drainage. We commenced the survey at the outlet of the drain to 8th Concession Drain North. We then proceeded upstream along the channel to its head, westerly across a gravel parking lot (Roll No. 550-18600) to the west limit of Webster Drive.

Our survey revealed a significant amount of contaminated sediment in the drain.

In addition to the Demonte Branch Drain, we surveyed a portion of the 8th Concession Drain North from the outlet of the Demonte Branch Drain to the concrete box culvert on the south side of King's Highway No. 401. Our survey revealed a significant amount of vegetation with frequent accumulation of debris, forming blockages within the channel. There is a uniform buildup of sediment averaging approximately 200 mm (8 inches) above the design grade set out in the previous 2000 engineer's report which is being matched as shown on the new design profile appended herein.

Existing Conditions and Recommendations

The last report for repair and improvement of the drain was completed in 2000. The open drain portion will require a bottom cleanout to align with the 2000 design profile as shown on the drawings attached. Generally the drain banks appear to be stable but not well grassed.

Contamination of the enclosed 900 mm diameter private drain and the 600 mm diameter enclosed part of the Demonte Branch Drain had been identified by the Town and the contaminated sediment was subsequently removed by the landowner responsible. The Ministry, at that time, Ministry of the Environment and Climate Change was involved. Sampling of the water, drain banks and sediment in the open drain was completed by Dillon and the analysis found contamination in the water and sediment but not in the soil of the drain banks. These findings have been summarized under a separate memorandum.

Upstream of the Demonte Branch Drain there exists approximately 161 metre length of 900 mm diameter concrete storm pipe connected to the drain. The storm sewer was installed under an agreement dated September 9, 1982 between the owner of the upstream lands and the Husky property. The agreement provided the right for the upstream landowner to construct and maintain the enclosed drain through the Husky lands. The enclosed drain serves the drainage needs for Webster Drive and the upstream lands which have changed ownership since the 1982 agreement. It is understood that there is an orifice at the upstream end of the pipe which shall be

removed as part of this work to better facilitate drainage from the upstream lands. We recommend it be incorporated as part of the municipal drainage works and shall be named the Demonte Branch Drain.



The access bridges were inspected during the course of our investigation. These bridges provide access from a private right-of-way to the adjacent lands. Our assessment identified culverts that are in poor condition and that are still in serviceable condition, but will likely require replacement in the next 5 to 10 years. Our analysis found Bridge No. 1 and 3 will require immediate replacement. Bridge No. 2 is still in reasonable condition and we have provided specifications for future replacement.

Specific structure numbers have been designated for ease of reference between specifications and the drawings.

The locations, dimensions, condition and use of each structure are as follows:

Bridge No. 1: Station 0+010 (Roll No. 550-17800 Laval Tool & Mould Ltd.)

A 13.2 m long, 600 mm diameter corrugated steel pipe with rip rap end protection and an asphalt driveway surface provides access to this property. This culvert was shown as a 600 mm diameter CSP in the 2000 report. This culvert is deficient in hydraulic capacity and requires immediate replacement.

We recommend that the culvert be replaced with a new 16.0 m long, 1150 x 820 mm aluminized corrugated steel pipe arch complete with sloped stone end walls, filter fabric underlay and providing a minimum 7.3 m driveable top width.

Bridge No. 2: Station 0+055 (Roll No. 550-17800 Laval Tool & Mould Ltd.)

A 31.0 m long, 1150 x 820 mm corrugated steel pipe arch with rip rap end protection and an asphalt driveway surface provides access to this property. This culvert was shown as a 750 mm diameter CSP in the 2000 report. The culvert is in good condition and does not require replacement at the present time.

We recommend that in the future, the culvert be replaced with a new 35.0 m long, 1150 x 820 mm aluminized corrugated steel pipe arch complete with sloped stone end walls, filter fabric underlay and providing a minimum 28.0 m driveable top width.

Bridge No. 3: Station 0+091 (Roll No. 550-17800 Laval Tool & Mould Ltd.)

A 10.5 m long, 700 mm diameter corrugated steel pipe with rip rap end protection and an asphalt driveway surface provides access to this property. This culvert was shown as a 750 mm diameter CSP in the 2000 report. This culvert is deficient in hydraulic capacity and requires immediate replacement.

We recommend that the culvert be replaced with a new 12.5 m long, 1150 x 820 mm aluminized corrugated steel pipe arch complete with sloped stone end walls, filter fabric underlay and providing a minimum 6.1 m driveable top width.

Bridge No. 4: Station 0+205 (Roll No. 550-17900 R.J. Cyr Co. Inc.)

A 42.0 m long, 600 mm diameter HDPE complete with sloped stone end wall and asphalt driveway surface provides access to this property. This culvert is in good condition but lacks hydraulic capacity.

We recommend that the culvert be replaced with a new 65.0 m long, 1150 x 820 mm polymer laminated corrugated steel pipe arch complete with sloped stone end wall, filter fabric underlay and providing a minimum 30.0 m driveable top width.

The private existing 900 mm diameter storm sewer and manholes and the 600 mm diameter closed portion located across the Husky property (Roll No. 550-18600) were filled with water and required flushing as part of the Ministry's order to make an observation if they required replacement. A video inspection of the existing pipes found the pipes to be in good condition but were holding contaminated soils. The contaminated material was disposed of off-site by the landowner. From the video inspection, a concrete block wall was visible near Manhole No. 3. We recommend this wall be removed to provide an outlet for Webster Drive.

Based on a legal review of the agreement, it is understood that the municipality has the right to access and maintain the pipe, however, there is no mechanism to assess the costs. Adoption of this report would provide the right for drainage, access, maintenance and assessment of the associated costs.

The municipality will be undertaking the reconstruction of Webster Drive including road reconstruction, storm sewers, sanitary sewers and watermain replacement which requires a legal outlet for the proposed storm sewers. We therefore recommend the existing private tile system be incorporated under the Drainage Act and be referred to as the Demonte Branch Drain.

Design Considerations

Typically for an area such as this, a 1:5 year design storm would be applied. However, the existing open drain is shallow and very flat which limits the opportunity for increasing the slope and in turn the capacity of the system. The extent to which the work could continue downstream was reviewed and it was found that the downstream section of the 8th Concession Drain is also quite flat. In addition, there is a concrete box culvert under King's Highway No. 401 which would be cost prohibitive to replace. Given the physical restraints of the Demonte and 8th Concession Drains, a 1:2 year level of service is recommended. As redevelopment of the adjacent lands occur, private stormwater measures will be required which account for the 1:2 year level of service.

Allowances

In accordance with Sections 29, 30 and 31 of the Drainage Act, we have made a determination of the amount to be paid for lands taken for the improvements to the drain as recommended, damages to lands and crops (if any), and for the incorporation of the existing sewer. Due to the contamination identified in the sediment, all excavated materials must be trucked away to a landfill.

As such, there are no damage allowances associated with spreading of excavated material under Section 30. Further, the construction area will have to be restored to existing, or better, conditions. As such, there are no damage allowances with respect to restoration on lands by the landowners.

The Section 29 allowance for land taken for the working corridor required for the newly incorporated 900 mm diameter concrete pipe drain is based on a corridor width of 15 metres centred on the alignment of the tile. The land currently consists of an open gravel parking lot. Accordingly, the Section 29 allowance has been calculated at a rate of \$25,000 per hectare.

The existing 900 mm diameter storm sewer located on the Husky property will be incorporated as part of the Demonte Branch Drain under this report. Therefore, under Section 31 of the Drainage Act an allowance of \$59,990.00 will be paid for the existing storm sewer. The amount of the allowance was developed by estimating the current value of a new sewer of similar size and material and applying a depreciation based on a comparison of the life expectancy of the pipe and its current age.

A private agreement established on September 9, 1982 between landowners established the easement for construction and maintenance of the private storm sewer. Since that time, the land ownership has changed.



Cost Estimate

Based on our review of the history, the information obtained during the site meeting and our examination and analysis of the survey data, we recommend that the Demonte Branch Drain be repaired and improved as described below:



Item	Description	Amount
<u>DEMONTE BRANCH DRAIN-OPEN DRAIN WORK</u>		
1.	Excavation and trucking of excavated materials works for the Demonte Branch Drain, as follows:	
	a) Excavation of the drain bottom only, as follows:	
	i) Station 0+000 to Station 0+184, totalling approximately 184 lineal metres of drain and approximately 65 m ³ of material.	\$2,650.00
	b) Trucking and disposal of all excavated, contaminated materials to landfill site, as follows:	
	i) At all properties totalling approximately 65 m ³ of material. (Trucking and hauling costs only)	\$2,600.00
	ii) Disposal of contaminated material off-site (approximately 130 tonnes).	\$7,200.00
2.	Excavation and trucking of excavated materials works for the 8 th Concession Drain North including removal and reinstallation of chain fence for access and costs for encroachment permit to work in vicinity of King's Highway No. 401, as follows:	
	a) Excavation of the drain bottom only, as follows:	
	i) Station 1+915A to Station 2+000A, totalling approximately 85 lineal metres of drain and approximately 25 m ³ of material.	\$1,100.00
	b) Trucking and disposal of all excavated, contaminated materials to landfill site, as follows:	
	i) At all properties totalling approximately 25 m ³ of material. (Trucking and hauling costs only)	\$1,000.00
	ii) Disposal of contaminated material off-site (approximately 50 tonnes).	\$2,900.00
3.	Cable concrete drain liner, as follows:	
	a) Station 0+017 to Station 0+039 and Station 0+070 to Station 0+084 - Supply and install 230 m ² CC35 cable concrete mats with stainless steel anchors. Contractor designed drawings required, sealed by Ontario Professional Engineer.	\$32,000.00

4.	Private access bridge replacement works, as follows:	
	a) <u>Bridge No. 1</u> - Station 0+010 (Roll No. 550-17800) – Removal and disposal of existing 13.2 m long 600 mm diameter CSP, existing end walls and backfill off-site that are not suitable for native backfill.	\$13,650.00
	Installation of a new 16.0 m long, 1150 x 820 mm corrugated steel pipe arch (CSPA). complete with clear stone bedding up to pipe springline with filter fabric overlay (approximately 30 tonnes), full Granular ‘A’ backfill from springline to underside of driveway surface material (approximately 80 m ³) compacted providing a minimum 7.3 m (24 ft.) driveable top width, clean native surface layer beyond driveway (approximately 20 m ³) and sloping stone end walls with filter fabric underlay (approximately 20 m ²). All surplus native materials resulting from the culvert installation are to be trucked away to an approved dumping site at the Contractor’s expense.	
	b) <u>Bridge No. 1</u> – Asphalt driveway restoration. Supply and install 80 mm HL3 layer (approx. 10 tonnes) in 2 equal lifts of 40 mm thickness, compacted.	\$3,500.00
	c) <u>Bridge No. 3</u> – Station 0+091 (Roll No. 550-17800) – Removal and disposal of existing 10.5 m long 700 mm diameter CSP, existing end walls and backfill off-site that are not suitable for native backfill. Supply and installation of a new 12.5 m long, 1150 x 820 mm corrugated steel pipe arch (CSPA). complete with clear stone bedding up to pipe springline with filter fabric overlay (approximately 25 tonnes), full Granular ‘A’ backfill from springline to underside of driveway surface material (approximately 60 m ³) compacted providing a minimum 6.1 m (20 ft.) driveable top width, clean native surface layer beyond driveway (approximately 20 m ³) and sloping stone end walls with filter fabric underlay (approximately 20 m ²). All surplus native materials resulting from the culvert installation are to be trucked away to an approved dumping site at the Contractor’s expense.	\$13,300.00
	d) <u>Bridge No. 3</u> – Asphalt driveway restoration. Supply and install 80 mm HL3 layer (approx. 10 tonnes) in 2 equal lifts of 40 mm thickness, compacted.	\$3,500.00
	e) <u>Bridge No. 4</u> – Station 0+216 (Roll No. 550-17900) – Removal and disposal of existing 42.0 m long 600 mm diameter HDPE, existing end walls and backfill off-site that are not suitable for native backfill. Supply and installation of a new 65.0 m long, 1150 x 820 mm polymer laminated corrugated steel pipe arch (CSPA). complete with clear stone bedding up to pipe	\$51,350.00



	springline with filter fabric overlay (approximately 110 tonnes), full Granular 'A' backfill from springline to underside of driveway surface material (approximately 320 m ³) compacted providing a minimum 30.0 m (98 ft.) driveable top width, clean native surface layer beyond driveway (approximately 20 m ³) and sloping stone end walls with filter fabric underlay (approximately 15 m ²). All surplus native materials resulting from the culvert installation are to be trucked away to an approved dumping site at the Contractor's expense.	
	f) <u>Bridge No. 4</u> – Asphalt driveway restoration. Supply and install 80 mm HL3 layer (approx. 65 tonnes) in 2 equal lifts of 40 mm thickness, compacted.	\$22,200.00
5.	Access bridge cleaning works, as follows:	
	a) <u>Bridge No. 2</u> -Roll No. 550-17800 – Clean existing 1150 x 820 mm CSPA bridge (31 m long).	\$1,900.00
6.	Temporary Silt Control Measures During Construction	\$900.00
SUB-TOTAL		\$159,750.00
7.	Survey, Report, Assessment and Final Inspection (cost portion)	\$32,250.00
8.	Expenses and incidentals (cost portion)	\$3,000.00
9.	Environmental field services, sampling, analysis and reporting (cost portion)	\$4,900.00
10.	ERCA application review and permit fee	\$800.00
TOTAL ESTIMATE – DEMONTE BRANCH DRAIN		\$200,700.00

<u>SECTION 26 NON PRO-RATABLE COSTS</u>		
11.	Road bridge cleaning works, as follows:	
	a) Cleaning of existing 1520 mm x 1220 mm box culvert, 55 m long under King's Highway No. 401. Work shall include disposal of materials off-site and all costs to obtain MTO permits.	\$16,000.00
SUB-TOTAL SECTION 26 NON PRO-RATABLE COSTS		\$16,000.00
12.	Engineering cost apportionment	\$1,000.00
TOTAL SECTION 26 NON PRO-RATABLE COSTS		\$17,000.00

TOTAL ESTIMATE – DEMONTE BRANCH DRAIN		\$217,700.00
--	--	---------------------

DEMONTE BRANCH DRAIN (CLOSED DRAIN)		
1.	Remove existing concrete block wall inside existing MH3.	\$1,000.00
SUB-TOTAL		\$1,000.00
2.	Allowances under Section 29 and 31	\$65,990.00
3.	Survey, Report, Assessment and Final Inspection (cost portion)	\$15,650.00
4.	Expenses and incidentals (cost portion)	\$1,500.00
5.	Environmental field services, sampling, analysis and reporting (cost portion)	\$10,000.00
TOTAL DEMONTE BRANCH DRAIN (CLOSED DRAIN)		\$94,140.00



OVERALL TOTAL ESTIMATE DEMONTE BRANCH DRAIN	\$311,840.00
--	---------------------

The estimate provided in this report was prepared according to current materials and installation prices as of the date of this report. In the event of delays from the time of filing of the report by the Engineer to the time of tendering the work, it is understood that the estimate of cost is subject to inflation. The rate of inflation shall be calculated using the Consumer Price Index applied to the cost of construction from the date of the report to the date of tendering.

Assessment of Costs

The individual assessments are comprised of three (3) assessment components:

- i. Benefit (advantages relating to the betterment of lands, roads, buildings, or other structures resulting from the improvement to the drain).*
- ii. Outlet Liability (part of cost required to provide outlet for lands and roads).*
- iii. Special Benefit (additional work or feature that may not affect function of the drain).*

Assessment Rationale – Open Drain Improvements

We have assessed the above estimated costs for the repair and improvement of the Demonte Branch Drain and the 8th Concession Drain North (Station 1+915A to Station 2+000A) against the affected lands and roads listed in Schedule “C-1” under “Benefit” and “Outlet Liability” or Special Benefit assessments shown in Schedule “C-1” are detailed in Schedule “D-1.” Assessments were derived as follows:

1. The above estimated costs have been assessed 60% as a Benefit assessment and 40% as an Outlet Liability assessment against all upstream lands and roads within the drainage area.

2. Any costs associated with an Encroachment permit for work done on the 8th Concession Drain shall be assessed 100% to the Ministry of Transportation under Section 26 of the Drainage Act.
3. Costs associated with the cable concrete liner shall be assessed against the abutting properties, 50% to Laval Tool Mould Ltd. (Roll No. 550-17800) and 50% to 679637 Ontario Ltd. (Roll No. 550-18000).

Assessment Rationale for Special Benefit Assessments (Bridges)

Special Benefit assessment shown in Schedule ‘C-1’ and detailed in Schedule ‘D-1’ were derived as follows:

1. Bridge replacement costs for Bridge No. 1 (Primary) assessed 50% to abutting property Roll No. 550-17800. The remaining 50% is assessed to upstream lands within the Demonte Branch Drain watershed. The assessment shall be a pro-ratable assessment.
2. An engineering cost portion of \$2,500.00 for the design provisions on the future replacement of Bridge No. 2 (Secondary) has been assessed 100% against the abutting property (Roll No. 550-17800). The assessment shall be a pro-ratable assessment.
3. Bridge replacement costs for Bridge No. 3 (Secondary) assessed 100% to abutting property Roll No. 550-17800. The assessment shall be a pro-ratable assessment.
4. Bridge replacement costs for Bridge No. 4 (Primary) assessed 50% to abutting property Roll No. 550-17900. The remaining 50% is assessed to upstream lands within the Demonte Branch Drain watershed. The assessment shall be a pro-ratable assessment.
5. Increased costs to provide asphalt and concrete driveway surfaces have been assessed 100% against the adjacent landowner. The assessment shall be a non-proratable assessment.
4. Bridge cleaning costs for Highway 401 bridge has been assessed 100% to the Ministry of Transportation Ontario. The assessments shall be a non-proratable assessment.

Assessment Rationale-Demonte Branch Drain (Closed Drain)

We have assessed the above estimated costs for the repair and improvement of the closed portion of the Demonte Branch Drain against the affected lands and roads listed in Schedule “C-2” under “Benefit” and “Outlet Liability” and detailed in Schedule “D-2.”

The costs of the Section 31 allowances shall be assessed as a Special Benefit to the lots within the Webster Drive subdivision in equal proportions. The assessments shall be a non-proratable assessment.

Utilities

It may become necessary to temporarily or permanently relocate utilities that may conflict with the construction recommended under this report. In accordance with Section 26 of the Drainage Act, we assess any relocation cost against the public utility having jurisdiction.

Under Section 69 of the Drainage Act, the public utility is at liberty to do the work with its own forces, but if it should not exercise this option within a reasonable time, the Municipality will arrange to have this work completed and the costs will be charged to the appropriate public utility.

Future Maintenance (Demonte Branch Drain) (Open Drain)

After completion, the Demonte Branch Drain shall be maintained by the Town of Tecumseh at the expense of the lands and road herein assessed in Schedule E-1,” and in the same relative proportions subject, of course, to any variations that may be made under the authority of the Drainage Act. The portion of the 8th Concession Drain North (Station 1+915A to Station 2+000A) shall be maintained by the Town of Tecumseh under this report at the expense of the lands and road herein assessed in Schedule E-1,” and in the same relative proportions subject, of course, to any variations that may be made under the authority of the Drainage Act. The assessments are based on an arbitrary amount of \$10,000.00. Tile inlet repairs and stone erosion protection shall be assessed 100% against the property on which the tile or surface water inlet serves.

Future Maintenance (Demonte Branch Drain) (Closed Drain)

The Demonte Branch Drain shall be maintained by the Town of Tecumseh at the expense of the lands and road herein assessed in Schedule E-2,” and in the same relative proportions subject, of course, to any variations that may be made under the authority of the Drainage Act. The assessments are based on an arbitrary amount of \$10,000.00.



Future Maintenance (Private Access Bridges)

We recommend that future work of repair and maintenance of the Demonte Branch Drain private access bridges be carried out by the Town of Tecumseh at the expense of the property or properties accessed by the bridge and of the lands and roads shown in Schedule “E-3”, but only to those properties located upstream of each bridge.

Part of the maintenance cost of each bridge will be assessed as a Special Benefit assessment against the property or properties served by the bridge.

The remainder of the maintenance cost will be assessed as Outlet assessment only to the lands and roads upstream of each bridge prorated to the assessments shown in Schedule “E-3.”

Schedule “E-3” represents all the lands and roads upstream of Bridge No. 1 and is applicable to other primary access bridges located further upstream by including only those properties that are upstream of the said bridge. The assessment is based on an arbitrary amount of \$10,000.00 of future access bridge maintenance costs.

The division between Special Benefit and Outlet assessment for each bridge shall be as follows:

Bridge No.	Type	Owner(s)	Special Benefit	Outlet
1	Primary	Roll No. 550-17800	50%	50%
2	Secondary	Roll No. 550-17800	100%	0%
3	Secondary	Roll No. 550-17800	100%	0%
4	Primary	Roll No. 550-17900	50%	50%

Drawings and Specifications

Attached to this report is Schedule ‘F’, which are Specifications setting out the details of the recommended works and Schedule ‘G’ which represent the drawings that are attached to this report.

- Page 1 of 5 - Watershed Plan**
- Page 2 of 5 - Detail Plan**
- Page 3 of 5 - Profile**
- Page 4 of 5 - Cross Sections & Details**
- Page 5 of 5 - Bridge Details**

Approvals

The construction and/or improvement to a drainage works, including repair and maintenance activities, and all operations connected therewith are subject to the approval, inspection, by-laws and regulations of all Municipal, Provincial, Federal and other authorities having jurisdiction in respect to any matters embraced by the proposed works. Prior to any construction or maintenance works, the Municipality or proponent designated on the Municipality's behalf shall obtain all required approvals/permits and confirm any construction limitations including timing windows, mitigation/off-setting measures, standard practices or any other limitations related to in-stream works.

Grants

In accordance with the provisions of Sections 85, 86 and 87 of the Drainage Act, a grant in the amount of 33-1/3 percent of the assessment eligible for a grant may be made in respect to the assessment made under this report upon privately owned lands used for agricultural purposes. The assessments levied against privately owned agricultural land must also satisfy all other eligibility criteria set out in the Agricultural Drainage Infrastructure Program policies. We understand that there are no agricultural lands and therefore no grants are anticipated.

Respectfully submitted,

DILLON CONSULTING LIMITED



Mark D. Hernandez, P.Eng.

MDH:wlb:mc

File No. 17-5617





MEETING MINUTES

Subject: Petition Drain-Webster Drive
Date and Time: May 2, 2017
Location: 3800 Webster Drive
Our File: 17-5617

Attendees

Phil Bartnik	Town of Tecumseh
Stephanie Kiritsis	Town of Tecumseh
Gerry Chauvin	Town of Tecumseh
Sam Paglia	Town of Tecumseh
Mark Hernandez	Dillon Consulting
Danny Vujdic	ECM

Notes

Item	Discussion	Action By
1.	Need to take samples from existing Demonte	
1.1.	<ul style="list-style-type: none"> Likely contaminated. Call Ministry of Environment if required. If single source is confirmed then the landowner pays. If not, it would be a drain cost 	
2.	Section 4 petition	
2.1.	Existing private drain from Station 0+252 to right-of-way. The condition is unknown at this time and needs to be located. Discussion with Husky may be required.	
2.2.	The Town intends to reconstruct Webster Drive and requires a formal outlet for the right-of-way.	
3.	Stormwater Management concerns	
3.1.	It was discussed that the industrial area along Webster Drive has issues with stormwater management. It was discussed that in one case, stormwater flows overland through the building. It was discussed that at some point each property will require stormwater measures for quantity and quality control.	

4. Survey

- 4.1. A survey will have to be completed to determine sufficient outlet. It was discussed that the survey should start at the culvert under Hwy 401. It was discussed that there may be limited grade available in the existing drains to improve the system.

5. Drain Name

- 5.1. Naming will have to be considered, ie. Branch drain extension

6. Drainage Act Process

- Survey
- Report Preparation
- PIC Meeting (Public Information Centre)
- Meeting to Consider
- Court of Revision

Errors and/or Omissions

These minutes were prepared by Mark Hernandez who should be notified of any errors and/or omissions.

Meeting Minutes

Subject: Demonte Drain
Date: November 5, 2021
Location: In front of Quick Draw Tarpaulin Systems
Our File: 17-5617

Attendees

Sam Paglia	Town of Tecumseh
Walt Demonte	Landowner
Mark Hernandez	Dillon Consulting Limited

Notes

Item	Discussion	Action
1.	<p>A summary of the meeting is as follows:</p> <ul style="list-style-type: none"> The Town received a request from RJ Cyr for an additional access to their property as part of their site development. Mr. Demonte indicated that no one from RJ Cyr spoke with him about the request. A temporary culvert had been installed by a contractor for RJ Cyr which was subsequently removed at the direction of the Town. Mr. Demonte indicated that the private roadway is congested and that the additional access would worsen the situation for Mr. Demonte. Mr. Demonte owns the private roadway. Mr. Demonte confirmed he would not support, and would appeal the report if it were to proceed with the culvert requested by RJ Cyr. It was discussed that RJ Cyr has the right to request the culvert, but that request is subject to approvals in addition to the Drainage Act process, including ERCA and Road Authority approvals. This is no different than requests on other municipal drains. It was discussed that RJ Cyr would be notified that Mr. Demonte is not in agreement and so the report cannot proceed with the requested culvert. It was discussed that the additional culvert requested by RJ Cyr could be contained within its own report at a later date. Agreement from Mr. Demonte would still be required. 	

Item	Discussion	Action
-------------	-------------------	---------------

- It was discussed that other landowners require the balance of the work contained within the draft report to proceed and it is undesirable to delay the works.

Errors and/or Omissions

These minutes were prepared by Mark Hernandez, P.Eng. who should be notified of any errors and/or omissions.

Meeting Minutes

Subject: Demonte Drain
Date: December 16, 2021
Location: Virtual Meeting
Our File: 17-5617

Attendees

Sam Paglia	Town of Tecumseh
John Henderson	Town of Tecumseh
David Meade	Windsor Industrial Services
Nick Rosati	Rosati Group
Denis Gauthier	Rosati Group
Mark Hernandez	Dillon Consulting Limited

Notes

Item	Discussion	Action
1.	<p>A summary of the meeting is as follows:</p> <ul style="list-style-type: none"> • A meeting was held with Mr. Demonte on November 5, 2021. • Mr. Demonte indicated that no one from RJ Cyr spoke with him about the request for a new culvert / access. Mr. Demonte owns the private roadway. • Mr. Demonte had indicated that the private roadway is congested and that the additional access would worsen the situation for Mr. Demonte. • Mr. Demonte confirmed he would not support, and would appeal the report if it were to proceed with the culvert requested by RJ Cyr. • It was discussed that RJ Cyr has the right to request the culvert, but that request is subject to approvals in addition to the Drainage Act process, including ERCA and Road Authority approvals. This is no different than requests on other municipal drains. • As Mr. Demonte is not in agreement the report cannot proceed with the requested culvert. • It was discussed that the additional culvert requested by RJ Cyr could be contained within its own report at a later date. <p>Agreement from Mr. Demonte would still be required.</p>	

Item	Discussion	Action
	<p>It is understood that RJ Cyr will be reviewing their legal agreements to understand what right of access they currently have.</p> <ul style="list-style-type: none"> <li data-bbox="386 378 1279 491">• It was discussed that other landowners require the balance of the work contained within the draft report to proceed and it is undesirable to delay the works. <li data-bbox="386 508 1260 621">• Mr. Meade confirmed that they would not pursue the additional access further at this time and that this would be confirmed in writing. 	

Errors and/or Omissions

These minutes were prepared by Mark Hernandez, P.Eng. who should be notified of any errors and/or omissions.

"SCHEDULE B"
SCHEDULE OF ALLOWANCES
DEMONTÉ BRANCH DRAIN
TOWN OF TECUMSEH

Roll No.	Con.	Description	Owner	Section 31	Section 30 Damages	Section 29 Land	Total Allowances
550-18600	7	Pt. Lot 13 RP12R2282 Pts. 2-7 Pts. 10&13	Husky Oil Ltd.	\$8,570.00	\$0.00	\$6,000.00	\$14,570.00
550-18615	7	Pt. Lot 13 RP12R8957 Pts. 1&20	Bensav Real Estate Inc.	\$8,570.00	\$0.00	\$0.00	\$8,570.00
550-18614	7	Pt. Lot 13 RP12R8957 Pts. 2&19	1871418 Ontario Inc.	\$8,570.00	\$0.00	\$0.00	\$8,570.00
550-18612	7	Pt. Lot 13 RP12R8957 Pts. 3&18	Bensav Real Estate Inc.	\$8,570.00	\$0.00	\$0.00	\$8,570.00
550-18610	7	Pt. Lot 13 RP12R8957 Pt. Pts 4&17	Ministry of Transportation Ontario	\$8,570.00	\$0.00	\$0.00	\$8,570.00
550-02601	7	Pt. Lot 13 RP12R8957 Pts. 14-16	Toromont Industries Ltd.	\$8,570.00	\$0.00	\$0.00	\$8,570.00
550-18602	7	Pt. Lot 13 RP12R8957 Pts. 8-13	Barnum Property Holders Inc.	\$8,570.00	\$0.00	\$0.00	\$8,570.00
TOTAL ALLOWANCES				\$59,990.00	\$0.00	\$6,000.00	\$65,990.00

"SCHEDULE C-1"
SCHEDULE OF ASSESSMENT
DEMONTE BRANCH DRAIN
TOWN OF TECUMSEH
(Page 1 of 2)

ONTARIO LANDS:

Roll No.	Con.	Description	Area Affected (Acres) (Ha.)		Owner	Special Benefit	Benefit	Outlet	Total Assessment
550-18610	7	Pt. Lot 13 RP12R8957 Pts. 4&17	2.81	1.14	Ministry of Transportation Ontario	\$0.00	\$393.00	\$3,578.00	\$3,971.00
Total on Ontario Lands.....						\$0.00	\$393.00	\$3,578.00	\$3,971.00

MUNICIPAL LANDS:

Description	Area Affected (Acres) (Ha.)		Owner	Special Benefit	Benefit	Outlet	Total Assessment
Webster Drive	1.68	0.68	Town of Tecumseh	\$0.00	\$391.00	\$3,555.00	\$3,946.00
Total on Municipal Lands.....				\$0.00	\$391.00	\$3,555.00	\$3,946.00

PRIVATELY-OWNED - NON-AGRICULTURAL LANDS:

Roll No.	Con.	Description	Area Affected (Acres) (Ha.)		Owner	Special Benefit	Benefit	Outlet	Total Assessment
550-18615	7	Pt. Lot 13 RP12R8957 Pts. 1&20	2.90	1.17	Bensav Real Estate Inc.	\$0.00	\$477.00	\$4,333.00	\$4,810.00
550-18614	7	Pt. Lot 13 RP12R8957 Pts. 2&19	1.07	0.43	1871418 Ontario Inc.	\$0.00	\$149.00	\$1,350.00	\$1,499.00
550-18612	7	Pt. Lot 13 RP12R8957 Pts. 3&18	1.14	0.46	Bensav Real Estate Inc.	\$0.00	\$176.00	\$1,598.00	\$1,774.00
550-02601	7	Pt. Lot 13	2.47	1.00	Toromont Industries Ltd.	\$0.00	\$395.00	\$3,588.00	\$3,983.00
550-18602	7	Pt. Lot 13 RP12R8957 Pts. 8&13	3.00	1.21	Barnim Property Holdings Inc.	\$0.00	\$415.00	\$3,772.00	\$4,187.00
550-18600	7	Pt. Lot 13 RP12R2282 Pts. 2-7, Pts. 10&13	16.65	6.74	Husky Oil Ltd.	\$0.00	\$5,338.00	\$27,218.00	\$32,556.00
550-17900	7	Pt. Lot 13	5.05	2.04	R.J. Cyr. Co. Inc.	\$31,031.00	\$2,212.00	\$2,438.00	\$35,681.00
550-17800	7	S Pt. Lot 13	0.91	0.37	Laval Tool & Mould Ltd.	\$47,656.00	\$1,113.00	\$536.00	\$49,305.00
550-18000	7	Pt. Lots 12 & 13 RP12R2282 Pts. 8,9,11,12,14&15	1.11	0.45	679637 Ontario Ltd.	\$20,000.00	\$1,917.00	\$571.00	\$22,488.00
Total on Privately-Owned - Non-Agricultural Lands.....						\$98,687.00	\$12,192.00	\$45,404.00	\$156,283.00
TOTAL ASSESSMENT (Excl. Non-Proratable Assessments)						\$98,687.00	\$12,976.00	\$52,537.00	\$164,200.00

"SCHEDULE C-1"
SCHEDULE OF ASSESSMENT
DEMONTE BRANCH DRAIN
TOWN OF TECUMSEH
(Page 2 of 2)

PRIVATELY-OWNED - NON-AGRICULTURAL LANDS (NON-PRORATABLE):

Roll No.	Con.	Description	Area Affected (Acres) (Ha.)		Owner	Special Benefit	Benefit	Outlet	Total Assessment
550-17800	7	S Pt. Lot 13	0.00	0.00	Laval Tool & Mould Ltd.	\$8,750.00	\$0.00	\$0.00	\$8,750.00
550-17900	7	Pt. Lot 13	0.00	0.00	R.J. Cyr. Co. Inc.	\$27,750.00	\$0.00	\$0.00	\$27,750.00
Total on Privately-Owned - Non-Agricultural Lands (Non Pro-ratable).....						\$36,500.00	\$0.00	\$0.00	\$36,500.00

SECTION 26 INCREASED COSTS - NON PRO-RATABLE:

Roll No.	Con.	Description	Area Affected (Acres) (Ha.)		Owner	Special Benefit	Benefit	Outlet	Total Assessment
		Kin'g's Highway No. 401			Ministry of Transportation Ontario	\$17,000.00	\$0.00	\$0.00	\$17,000.00
Total Section 26 Increased Costs (Non Pro-ratable).....						\$17,000.00	\$0.00	\$0.00	\$17,000.00

TOTAL ASSESSMENT..... \$217,700.00

	(Acres)	(Ha.)
Total Area:	38.79	15.69

"SCHEDULE C-2"
SCHEDULE OF ASSESSMENT
DEMONTE BRANCH DRAIN (CLOSED DRAIN)
TOWN OF TECUMSEH

ONTARIO LANDS:

Roll No.	Con.	Description	Area Affected (Acres) (Ha.)		Owner	Special Benefit	Benefit	Outlet	Total Assessment
550-18610	7	Pt. Lot 13 RP12R8957 Pts. 1&17	2.81	1.14	Ministry of Transportation Ontario	\$8,570.00	\$123.00	\$822.00	\$9,515.00
Total on Ontario Lands.....						\$8,570.00	\$123.00	\$822.00	\$9,515.00

MUNICIPAL LANDS:

Roll No.	Con.	Description	Area Affected (Acres) (Ha.)		Owner	Special Benefit	Benefit	Outlet	Total Assessment
Webster Drive			1.68	0.68	Town of Tecumseh	\$0.00	\$123.00	\$818.00	\$941.00
Total on Municipal Lands.....						\$0.00	\$123.00	\$818.00	\$941.00

PRIVATELY-OWNED - NON-AGRICULTURAL LANDS:

Roll No.	Con.	Description	Area Affected (Acres) (Ha.)		Owner	Special Benefit	Benefit	Outlet	Total Assessment
550-18615	7	Pt. Lot 13 RP12R8957 Pts. 1&20	2.90	1.17	Bensav Real Estate Inc.	\$8,570.00	\$149.00	\$996.00	\$9,715.00
550-18614	7	Pt. Lot 13 RP12R8957 Pts. 2&19	1.07	0.43	1871418 Ontario Inc.	\$8,570.00	\$47.00	\$310.00	\$8,927.00
550-18612	7	Pt. Lot 13 RP12R8957 Pts. 3&18	1.14	0.46	Bensav Real Estate Inc.	\$8,570.00	\$55.00	\$367.00	\$8,992.00
550-02601	7	Pt. Lot 13	2.47	1.00	Toromont Industries Ltd.	\$8,570.00	\$124.00	\$825.00	\$9,519.00
550-18602	7	Pt. Lot 13 RP12R8957 Pts. 8&13	3.00	1.21	Barnim Property Holdings Inc.	\$8,570.00	\$130.00	\$867.00	\$9,567.00
550-18600	7	Pt. Lot 13 RP12R2282 Pts. 2-7, Pts. 10&12	16.65	6.74	Husky Oil Ltd.	\$14,570.00	\$16,139.00	\$6,255.00	\$36,964.00
Total on Privately-Owned - Non-Agricultural Lands.....						\$57,420.00	\$16,644.00	\$9,620.00	\$83,684.00
TOTAL ASSESSMENT						\$65,990.00	\$16,890.00	\$11,260.00	\$94,140.00

	(Acres)	(Ha.)
Total Area:	31.72	12.83

"SCHEDULE D-1"
DETAILS OF SPECIAL BENEFIT
DEMONTE BRANCH DRAIN (OPEN DRAIN)
TOWN OF TECUMSEH

SPECIAL BENEFIT ASSESSMENT
(GENERAL DESCRIPTION OF SPECIAL BENEFIT)

Roll No.	Owner	Item Description	Estimated Cost	Cost of Report	Special Benefit
550-17800	Laval Tool & Mould Ltd.	<u>Bridge No. 1</u> -Sta. 0+010 (Primary 50%)	\$6,825.00	\$1,706.00	\$8,531.00
550-17800	Laval Tool & Mould Ltd.	<u>Bridge No. 2</u> -Sta. 0+055 (Secondary 100%)	\$0.00	\$2,500.00	\$2,500.00
550-17800	Laval Tool & Mould Ltd.	<u>Bridge No. 3</u> -Sta. 0+091 (Secondary 100%)	\$13,300.00	\$3,325.00	\$16,625.00
550-17800	Laval Tool & Mould Ltd.	Cable Concrete Drain Liner (50%)	\$16,000.00	\$4,000.00	\$20,000.00
Total Roll No. 550-17800			\$36,125.00	\$11,531.00	\$47,656.00
550-17900	R.J. Cyr Co. Inc.	<u>Bridge No. 4</u> -Sta. 0+205 (Primary 50%)	\$24,825.00	\$6,206.00	\$31,031.00
550-18000	679637 Ontario Ltd.	Cable Concrete Drain Liner (50%)	\$16,000.00	\$4,000.00	\$20,000.00
Total Special Benefit Assessment (Pro-ratable).....			\$76,950.00	\$21,737.00	\$98,687.00

NON PRO-RATABLE COSTS

Roll No.	Owner	Item Description	Estimated Cost	Cost of Report	Special Benefit
550-17800	Laval Tool & Mould Ltd.	<u>Bridge No. 1</u> -Asphalt driveway surface (100%)	\$3,500.00	\$875.00	\$4,375.00
550-17800	Laval Tool & Mould Ltd.	<u>Bridge No. 3</u> -Asphalt driveway surface (100%)	\$3,500.00	\$875.00	\$4,375.00
Total Roll No. 550-17800			\$7,000.00	\$1,750.00	\$8,750.00
550-17900	R.J. Cyr Co. Inc.	<u>Bridge No. 4</u> -Asphalt driveway surface (100%)	\$22,200.00	\$5,550.00	\$27,750.00
Total Special Benefit Assessment (Non Pro-ratable).....			\$29,200.00	\$7,300.00	\$36,500.00

SECTION 26 (NON PRO-RATABLE COSTS)

Roll No.	Owner	Item Description	Estimated Cost	Cost of Report	Special Benefit
King's Highway No. 401	Ministry of Transportation	Clean ex. 1520 mm x 1220 mm concrete box culvert, 55 m long.	\$16,000.00	\$1,000.00	\$17,000.00
Total Special Benefit Assessment (Section 26 Non Pro-ratable).....			\$16,000.00	\$1,000.00	\$17,000.00
Overall Total Special Benefit Assessment.....					\$152,187.00

"SCHEDULE D-2"
DETAILS OF SPECIAL BENEFIT
DEMONTE BRANCH DRAIN (CLOSED DRAIN)
TOWN OF TECUMSEH

SPECIAL BENEFIT ASSESSMENT
(GENERAL DESCRIPTION OF SPECIAL BENEFIT)

Roll No.	Owner	Item Description	Estimated Cost	Cost of Report	Special Benefit
550-18600	Husky Oil Ltd.	Section 29 & 31 Allowances	\$14,570.00	\$0.00	\$14,570.00
550-18615	Bensav Real Estate Inc.	Section 31 Allowances	\$8,570.00	\$0.00	\$8,570.00
550-18614	1871418 Ontario Inc.	Section 31 Allowances	\$8,570.00	\$0.00	\$8,570.00
550-18612	Bensav Real Estate Inc.	Section 31 Allowances	\$8,570.00	\$0.00	\$8,570.00
550-18610	Ministry of Transportation Ontario	Section 31 Allowances	\$8,570.00	\$0.00	\$8,570.00
550-02601	Toromont Industries Ltd.	Section 31 Allowances	\$8,570.00	\$0.00	\$8,570.00
550-18602	Barnum Property Holdings Inc.	Section 31 Allowances	\$8,570.00	\$0.00	\$8,570.00
Total Special Benefit Assessment (Non Pro-ratable).....			\$65,990.00	\$0.00	\$65,990.00

"SCHEDULE E-1"
SCHEDULE OF ASSESSMENT FOR FUTURE MAINTENANCE
DEMONTE BRANCH DRAIN (OPEN DRAIN)
TOWN OF TECUMSEH

ONTARIO LANDS:

Roll No.	Con.	Description	Area Affected (Acres) (Ha.)		Owner	Special Benefit	Benefit	Outlet	Total Assessment
550-18610	7	Pt. Lot 13 RP12R8957 Pte 4&17	2.81	1.14	Ministry of Transportation Ontario	\$0.00	\$46.00	\$538.00	\$584.00
Total on Ontario Lands.....						\$0.00	\$46.00	\$538.00	\$584.00

MUNICIPAL LANDS:

Description	Area Affected (Acres) (Ha.)		Owner	Special Benefit	Benefit	Outlet	Total Assessment
Webster Drive	1.68	0.68	Town of Tecumseh	\$0.00	\$44.00	\$536.00	\$580.00
Total on Municipal Lands.....				\$0.00	\$44.00	\$536.00	\$580.00

PRIVATELY-OWNED - NON-AGRICULTURAL LANDS:

Roll No.	Con.	Description	Area Affected (Acres) (Ha.)		Owner	Special Benefit	Benefit	Outlet	Total Assessment
550-18615	7	Pt. Lot 13 RP12R8957	2.90	1.17	Bensav Real Estate Inc.	\$0.00	\$55.00	\$653.00	\$708.00
550-18614	7	Pte 1&20 Pt. Lot 13 RP12R8957	1.07	0.43	1871418 Ontario Inc.	\$0.00	\$17.00	\$203.00	\$220.00
550-18612	7	Pte 2&10 Pt. Lot 13 RP12R8957	1.14	0.46	Bensav Real Estate Inc.	\$0.00	\$20.00	\$241.00	\$261.00
550-02601	7	Pte 3&18 Pt. Lot 13	2.47	1.00	Toromont Industries Ltd.	\$0.00	\$46.00	\$540.00	\$586.00
550-18602	7	Pt. Lot 13 RP12R8957	3.00	1.21	Barnim Property Holdings Inc.	\$0.00	\$48.00	\$568.00	\$616.00
550-18600	7	Pte 8&13 Pt. Lot 13 RP12R2282	16.65	6.74	Husky Oil Ltd.	\$0.00	\$617.00	\$4,099.00	\$4,716.00
550-17900	7	Pts. 2-7, Pts. 10&12 Pt. Lot 13	5.05	2.04	R.J. Cyr. Co. Inc.	\$0.00	\$256.00	\$751.00	\$1,007.00
550-17800	7	S Pt. Lot 13	0.91	0.37	Laval Tool & Mould Ltd.	\$0.00	\$129.00	\$173.00	\$302.00
550-18000	7	Pt. Lots 12 & 13 RP 12R2282 Parts 8 9 11 12 14 and 15	1.11	0.45	679637 Ontario Ltd.	\$0.00	\$222.00	\$198.00	\$420.00
Total on Privately-Owned - Non-Agricultural Lands.....						\$0.00	\$1,410.00	\$7,426.00	\$8,836.00
TOTAL ASSESSMENT						\$0.00	\$1,500.00	\$8,500.00	\$10,000.00

(Acres) (Ha.)
Total Area: 38.79 15.69

"SCHEDULE E-2"
SCHEDULE OF ASSESSMENT FOR FUTURE MAINTENANCE
DEMONTE BRANCH DRAIN (CLOSED DRAIN)
TOWN OF TECUMSEH

ONTARIO LANDS:

Roll No.	Con.	Description	Area Affected (Acres) (Ha.)		Owner	Special Benefit	Benefit	Outlet	Total Assessment
550-18610	7	Pt. Lot 13 RP12R8957 Pts. 1&17	2.81	1.14	Ministry of Transportation Ontario	\$0.00	\$44.00	\$292.00	\$336.00
Total on Ontario Lands.....						\$0.00	\$44.00	\$292.00	\$336.00

MUNICIPAL LANDS:

Roll No.	Con.	Description	Area Affected (Acres) (Ha.)		Owner	Special Benefit	Benefit	Outlet	Total Assessment
Webster Drive			1.68	0.68	Town of Tecumseh	\$0.00	\$43.00	\$291.00	\$334.00
Total on Municipal Lands.....						\$0.00	\$43.00	\$291.00	\$334.00

PRIVATELY-OWNED - NON-AGRICULTURAL LANDS:

Roll No.	Con.	Description	Area Affected (Acres) (Ha.)		Owner	Special Benefit	Benefit	Outlet	Total Assessment
550-18615	7	Pt. Lot 13 RP12R8957 Pts. 1&20	2.90	1.17	Bensav Real Estate Inc.	\$0.00	\$53.00	\$354.00	\$407.00
550-18614	7	Pt. Lot 13 RP12R8957 Pts. 2&19	1.07	0.43	1871418 Ontario Inc.	\$0.00	\$17.00	\$110.00	\$127.00
550-18612	7	Pt. Lot 13 RP12R8957 Pts. 3&18	1.14	0.46	Bensav Real Estate Inc.	\$0.00	\$20.00	\$130.00	\$150.00
550-02601	7	Pt. Lot 13	2.47	1.00	Toromont Industries Ltd.	\$0.00	\$44.00	\$293.00	\$337.00
550-18602	7	Pt. Lot 13 RP12R8957 Pts. 8&13	3.00	1.21	Barnim Property Holdings Inc.	\$0.00	\$46.00	\$308.00	\$354.00
550-18600	7	Pt. Lot 13 RP12R2282 Pts. 2-7, Pts. 10&12	16.65	6.74	Husky Oil Ltd.	\$0.00	\$5,733.00	\$2,222.00	\$7,955.00
Total on Privately-Owned - Non-Agricultural Lands.....						\$0.00	\$5,913.00	\$3,417.00	\$9,330.00

TOTAL ASSESSMENT **\$0.00 \$6,000.00 \$4,000.00 \$10,000.00**

	(Acres)	(Ha.)
Total Area:	31.72	12.83

"SCHEDULE E-2"
SCHEDULE OF ASSESSMENT FOR FUTURE MAINTENANCE
DEMONTE BRANCH DRAIN EXTENSION
TOWN OF TECUMSEH

ONTARIO LANDS:

Roll No.	Con.	Description	Area Affected (Acres) (Ha.)		Owner	Special Benefit	Benefit	Outlet	Total Assessment
550-18610	7	Pt. Lot 13 RP12R8957 Pte 1&17	2.81	1.14	Ministry of Transportation	\$0.00	\$46.00	\$538.00	\$584.00
Total on Ontario Lands.....						\$0.00	\$46.00	\$538.00	\$584.00

MUNICIPAL LANDS:

Description	Area Affected (Acres) (Ha.)		Owner	Special Benefit	Benefit	Outlet	Total Assessment
Webster Drive	1.68	0.68	Town of Tecumseh	\$0.00	\$44.00	\$536.00	\$580.00
Total on Municipal Lands.....				\$0.00	\$44.00	\$536.00	\$580.00

PRIVATELY-OWNED - NON-AGRICULTURAL LANDS:

Roll No.	Con.	Description	Area Affected (Acres) (Ha.)		Owner	Special Benefit	Benefit	Outlet	Total Assessment
550-18615	7	Pt. Lot 13 RP12R8957 Pte 1&20	2.90	1.17	Bensav Real Estate Inc.	\$0.00	\$55.00	\$653.00	\$708.00
550-18614	7	Pt. Lot 13 RP12R8957 Pte 2&10	1.07	0.43	1871418 Ontario Inc.	\$0.00	\$17.00	\$203.00	\$220.00
550-18612	7	Pt. Lot 13 RP12R8957 Pte 3&18	1.14	0.46	Bensav Real Estate Inc.	\$0.00	\$20.00	\$241.00	\$261.00
550-18605	7	Pt. Lot 13	2.47	1.00	Toromont Industries Ltd.	\$0.00	\$46.00	\$540.00	\$586.00
550-18602	7	Pt. Lot 13 RP12R8957 Pte 8&13	3.00	1.21	Barnim Property Holdings Inc.	\$0.00	\$48.00	\$568.00	\$616.00
550-18600	7	Pt. Lot 13 RP12R2282 Pts. 2-7, Pts. 10&12	16.65	6.74	Husky Oil Ltd.	\$0.00	\$617.00	\$4,099.00	\$4,716.00
550-17900	7	Pt. Lot 13	5.05	2.04	R.J. Cyr. Co. Inc.	\$0.00	\$256.00	\$751.00	\$1,007.00
550-17800	7	S Pt. Lot 13	0.91	0.37	Laval Tool & Mould Ltd.	\$0.00	\$129.00	\$173.00	\$302.00
550-18000	7	Pt. Lots 12 & 13 RP 12R2282 Parts 8 9 11 12 14 and 15	1.11	0.45	679637 Ontario Ltd.	\$0.00	\$222.00	\$198.00	\$420.00
Total on Privately-Owned - Non-Agricultural Lands.....						\$0.00	\$1,410.00	\$7,426.00	\$8,836.00

TOTAL ASSESSMENT						\$0.00	\$1,500.00	\$8,500.00	\$10,000.00
			(Acres)	(Ha.)					
		Total Area:	38.79	15.69					

"SCHEDULE E-3"
SCHEDULE OF ASSESSMENT FOR FUTURE MAINTENANCE (BRIDGES)
DEMONTÉ BRANCH DRAIN
TOWN OF TECUMSEH

ONTARIO LANDS:

Roll No.	Con.	Description	Area Affected (Acres) (Ha.)		Owner	Special Benefit	Benefit	Outlet	Total Assessment
550-18610	7	Pt. Lot 13 RP12R8957 Pts. 4&17	2.81	1.14	Ministry of Transportation	\$0.00	\$0.00	\$607.00	\$607.00
Total on Ontario Lands.....						\$0.00	\$0.00	\$607.00	\$607.00

MUNICIPAL LANDS:

Description	Area Affected (Acres) (Ha.)		Owner	Special Benefit	Benefit	Outlet	Total Assessment
Webster Drive	1.68	0.68	Town of Tecumseh	\$0.00	\$0.00	\$603.00	\$603.00
Total on Municipal Lands.....				\$0.00	\$0.00	\$603.00	\$603.00

PRIVATELY-OWNED - NON-AGRICULTURAL LANDS:

Roll No.	Con.	Description	Area Affected (Acres) (Ha.)		Owner	Special Benefit	Benefit	Outlet	Total Assessment
550-18615	7	Pt. Lot 13 RP12R8957 Pts. 1&20	2.90	1.17	Bensav Real Estate Inc.	\$0.00	\$0.00	\$735.00	\$735.00
550-18614	7	Pt. Lot 13 RP12R8957 Pts. 2&19	1.07	0.43	1871418 Ontario Inc.	\$0.00	\$0.00	\$229.00	\$229.00
550-18612	7	Pt. Lot 13 RP12R8957 Pts. 3&18	1.14	0.46	Bensav Real Estate Inc.	\$0.00	\$0.00	\$271.00	\$271.00
550-18605	7	Pt. Lot 13	2.47	1.00	Toromont Industries Ltd.	\$0.00	\$0.00	\$609.00	\$609.00
550-18602	7	Pt. Lot 13 RP12R8957 Pts. 8&13	3.00	1.21	Barnim Property Holdings Inc.	\$0.00	\$0.00	\$640.00	\$640.00
550-18600	7	Pt. Lot 13 RP12R2282 Pts. 2-7, Pts. 10&13	16.65	6.74	Husky Oil Ltd.	\$0.00	\$0.00	\$4,618.00	\$4,618.00
550-17900	7	Pt. Lot 13	5.05	2.04	R.J. Cyr. Co. Inc.	\$0.00	\$0.00	\$1,057.00	\$1,057.00
550-17800	7	S Pt. Lot 13	0.91	0.37	Laval Tool & Mould Ltd.	\$0.00	\$0.00	\$316.00	\$316.00
550-18000	7	Pt. Lots 12 & 13 RP 12R2282 Parts 8 9 11 12 14 and 15	1.11	0.45	679637 Ontario Ltd.	\$0.00	\$0.00	\$315.00	\$315.00
Total on Privately-Owned - Non-Agricultural Lands.....						\$0.00	\$0.00	\$8,790.00	\$8,790.00

TOTAL ASSESSMENT						\$0.00	\$0.00	\$10,000.00	\$10,000.00
			(Acres)	(Ha.)					
Total Area:			38.79	15.69					

“SCHEDULE F”
DRAINAGE REPORT FOR THE
DEMONTE BRANCH DRAIN
TOWN OF TECUMSEH

SPECIAL PROVISIONS - GENERAL

1.0 GENERAL SPECIFICATIONS

The General Specifications attached hereto is part of “Schedule F.” It also forms part of this specification and is to be read with it, but where there is a difference between the requirements of the General Specifications and those of the Special Provisions which follow, the Special Provisions will take precedence.

2.0 DESCRIPTION OF WORK

The work to be carried out under this Contract includes, but is not limited to, the supply of all **labour, equipment and materials** to complete the following items:

OPEN DRAIN WORK

- Excavation and trucking of excavated materials works for the Demonte Branch Drain, as follows:
 - Excavation of the drain bottom only, as follows:
 - Station 0+000 to Station 0+184, totalling approximately 184 lineal metres of drain and approximately 65 m³ of material.
 - Trucking of all excavated, contaminated materials off-site, as follows:
 - At all properties totalling approximately 65 m³ of material.
 - Disposal of contaminated material off-site (approximately 130 tonnes).
- Excavation and trucking of excavated materials works for the 8th Concession Drain North including removal and reinstallation of chain fence for access, as follows:
 - Excavation of the drain bottom only, as follows:
 - Station 1+915A to Station 2+000A, totalling approximately 85 lineal metres of drain and approximately 25 m³ of material.
 - Trucking of all excavated, contaminated materials off-site, as follows:
 - At all properties totalling approximately 25 m³ of material.
 - Disposal of contaminated material off-site (approximately 50 tonnes).

- Cable concrete drain liner, as follows:
 - Station 0+017 to Station 0+039 and Station 0+070 to Station 0+084 - Supply and install 230 m² CC35 cable concrete mats with stainless steel anchors. Contractor designed drawings required, sealed by Ontario Professional Engineer.
- Private access bridge replacement works, as follows:
 - Bridge No. 1 - Station 0+010 (Roll No. 550-17800) – Removal and disposal of existing 13.6 m long 700 mm diameter CSP, existing end walls and backfill off-site that are not suitable for native backfill. Installation of a new 16.0 m long, 1150 x 820 mm corrugated steel pipe arch (CSPA). complete with clear stone bedding up to pipe springline with filter fabric overlay (approximately 30 tonnes), full Granular ‘A’ backfill from springline to underside of driveway surface material (approximately 80 m³) compacted providing a minimum 7.3 m (24 ft.) driveable top width, clean native surface layer beyond driveway (approximately 20 m³) and sloping stone end walls with filter fabric underlay (approximately 20 m²). All surplus native materials resulting from the culvert installation are to be trucked away to an approved dumping site at the Contractor’s expense.
 - Bridge No. 1 – Asphalt driveway restoration. Supply and install 80 mm HL3 layer (approx. 10 tonnes) in 2 equal lifts of 40 mm thickness, compacted.
 - Bridge No. 3 - Station 0+091 (Roll No. 550-17800) – Removal and disposal of existing 10.5 m long 700 mm diameter CSP, existing end walls and backfill off-site that are not suitable for native backfill. Installation of a new 12.5 m long, 1150 x 820 mm corrugated steel pipe arch (CSPA). complete with clear stone bedding up to pipe springline with filter fabric overlay (approximately 25 tonnes), full Granular ‘A’ backfill from springline to underside of driveway surface material (approximately 60 m³) compacted providing a minimum 6.1 m (20 ft.) driveable top width, clean native surface layer beyond driveway (approximately 20 m³) and sloping stone end walls with filter fabric underlay (approximately 20 m²). All surplus native materials resulting from the culvert installation are to be trucked away to an approved dumping site at the Contractor’s expense.
 - Bridge No. 3 – Asphalt driveway restoration. Supply and install 80 mm HL3 layer (approx. 10 tonnes) in 2 equal lifts of 40 mm thickness, compacted.

- Bridge No. 4 - Station 0+216 (Roll No. 550-17900) – Removal and disposal of existing 42.0 m long 600 mm diameter HDPE, existing end walls and backfill off-site that are not suitable for native backfill. Supply and installation of a new 65.0 m long, 1150 x 820 mm polymer laminated corrugated steel pipe arch (CSPA). complete with clear stone bedding up to pipe springline with filter fabric overlay (approximately 110 tonnes), full Granular ‘A’ backfill from springline to underside of driveway surface material (approximately 320 m³) compacted providing a minimum 30.0 m (98 ft.) driveable top width, clean native surface layer beyond driveway (approximately 20 m³) and sloping stone end walls with filter fabric underlay (approximately 15 m²). All surplus native materials resulting from the culvert installation are to be trucked away to an approved dumping site at the Contractor’s expense.
- Bridge No. 4 – Asphalt driveway restoration. Supply and install 80 mm HL3 layer (approx. 65 tonnes) in 2 equal lifts of 40 mm thickness, compacted.
- Private access bridge cleaning works, as follows:
 - Bridge No. 2-Roll No. 550-17800 – Clean existing 1150 x 820 mm CSPA (31 m long).
- Temporary Silt Control Measures During Construction
- Road bridge cleaning works, as follows:
 - Cleaning of existing 1520 mm x 1220 mm box culvert, 55 m long under King’s Highway No. 401. Work shall include disposal of materials off-site and all costs to obtain MTO permits.

3.0 ACCESS TO THE WORK

Access to the drain shall be from the private access road on Roll No 550-18000 and the gravel parking area on Roll No. 550-18600. The Contractor shall make his/her own arrangements for any additional access for his/her convenience. All road areas and grass lawn areas disturbed shall be restored to original conditions at the Contractor’s expense.

4.0 WORKING AREA

The Contractor shall restrict his equipment to the working corridors as specified in this Section. Any damage resulting from non-compliance with this Section, shall be borne by the Contractor. The working corridor shall be measured from the top of drain bank or centre of drain where applicable, and shall be as follows:

FROM	TO	WORKING CORRIDOR
0+000	0+184	<u>Demonte Branch Drain (Open Drain)</u> Existing private roadway on south side of drain (7.4 m wide)
0+184	0+249	<u>Demonte Branch Drain</u> 15.0 m wide (Centred over drain)
0+249	0+410	<u>Demonte Branch Drain (Closed Portion)</u> 15.0 m wide (Centred over drain)
1+915A	2+000A	<u>8th Concession Drain North (Open Drain)</u> Existing private parking/laneway (Roll No. 550-17800) on west side of drain (Note: Existing chain link fence to be removed during drain repair and reinstalled when completed. Construction of drainage works along 401 highway corridor will require an encroachment permit to be obtained by the Town of Tecumseh.

SPECIAL PROVISIONS – OPEN DRAIN

5.0 BRUSHING

Brushing shall be carried out on the entire drain within the above identified sections of the drain where required and as specified herein. **All** brush and trees located within the drain side slopes shall be cut parallel to the side slopes, as close to the ground as practicable. Tree branches that overhang the drain shall be trimmed. Small branches and limbs are to be disposed of by the Contractor along with the other brush. Tree stumps, where removed to facilitate the drain excavation and reshaping of the drain banks, may be burned by the Contractor where permitted; otherwise, they shall be disposed of, off the site. The Contractor shall make every effort to preserve mature trees which are beyond the drain side slopes, and the working corridors. If requested to do so by the Drainage Superintendent, the Contractor shall preserve certain mature trees within the designated working corridors (see Section 4.0).

Except as specified herein, all brush and trees shall be stockpiled adjacent to the drain within the working corridors. Stockpiles shall not be less than 100 m apart and shall be a minimum of 2.0 m from the edge of the drain bank. All brush, timber, logs, stumps, large stones or other obstructions and deleterious materials that interfere with the construction of the drain, as encountered along the course of the drain are to be removed from the drain by the Contractor. Large stones and other similar material shall be disposed of by the Contractor off the site.

Following completion of the work, the Contractor is to trim up any broken or damaged limbs on trees which remain standing, disposing of the branches cut off along with other brush and leaving the trees in a neat and tidy condition. Brush and trees removed from the working area are to be put into piles by the Contractor, in locations where they can be safely burned, and to be burned by the Contractor after obtaining the necessary permits, as required. If, in the opinion of the Drainage Superintendent, any of the piles are too wet or green to be burned, he shall so advise the Contractor to haul away the unburned materials to an approved dump site. Prior to, and during the course of burning operations, the Contractor shall comply with the current guidelines prepared by the Air Quality Branch of the Ontario Ministry of Environment and shall ensure that the Environmental Protection Act is not violated.

Since the trees and brush that are cut off flush with the earth surface may sprout new growth later, it is strongly recommended that the Municipality make arrangements for spraying this new growth at the appropriate time so as to kill the trees and brush.

As part of this work, the Contractor shall remove any loose timber, logs, stumps, large stones or other debris from the drain bottom and from the side slopes. **Timber, logs, stumps, large stones or other debris shall be disposed of off-site.**

6.0 EXCAVATION OF DRAIN BOTTOM

In all cases, the Contractor shall use the benchmarks to establish the proposed grade. However, for convenience, the drawings provide the approximate depth from the surface of the ground and from the existing drain bottom to the proposed grades. **THE CONTRACTOR SHALL NOT EXCAVATE DEEPER THAN THE GRADELINES SHOWN ON THE DRAWINGS.** Should over-excavation of the drain bank occur, the Contractor will **not** be permitted to repair with native material packed into place by the excavator and reshaped. Should over-excavation occur, the Contractor will be required to have a bank repair detail engineered by a Professional Engineer (hired by the Contractor), to ensure long term stability of the bank is maintained. Such repairs shall be subject to approval by the Engineer and will be at no extra cost to the item.

Seeding of the disturbed drain banks shall be completed immediately following drain construction and as specified in Section 17.

All excavation work shall be done in such a manner as to not harm any vegetation or trees, not identified in this report or by the Drainage Superintendent for clearing. Any damages to trees or vegetation caused by the Contractors work shall be rectified to the satisfaction of the Drainage Superintendent.

The Contractor shall exercise caution around existing tile inlets and shall confirm with the property owners that all tiles have been located and tile ends repaired as specified.

7.0 STONE EROSION PROTECTION (SEP)

The Contractor shall supply and install the required quantities of graded stone rip-rap erosion protection materials where specified. All stone to be used for erosion protection shall be 125 - 250 mm clear **quarried rock** or OPSS 1001 placed over a non-woven filter fabric Terrafix 270R or approved equivalent. **Concrete rip-rap will not be permitted.**

The minimum thickness requirement of the erosion stone layer is 300 mm with no portion of the filter fabric to be exposed.

8.0 EROSION PROTECTION – CABLE CONCRETE MATS

Erosion protection for the drain banks from Station 0+017 to Station 0+039 and Station 0+070 to Station 0+084 shall be constructed of cable concrete mats (IECS CC35 or approved equal), approximately 4.88 metres wide, as shown on the drawings and installed as per manufacturer's recommendations. The concrete mat shall be installed using stainless steel clamps. The concrete mats shall be installed with geotextile underlay. Contractor designed drawings are required to be sealed by an Ontario Professional Engineer.

9.0 CLEANING OF PRIVATE ACCESS CULVERTS AND ROAD BRIDGES

At the locations listed below, the Contractor shall clean the existing pipes or culverts to their full capacity and cross section or width. The operation may be carried out by mechanical means or by flushing. Any damage resulting from the Contractor's operation shall be rectified at his expense. All material removed from the pipes or culverts shall be transported to a landfill site arranged by the Contractor. The Contractor shall be solely responsible for acquiring all permits required for the work and dump site. The Contractor shall take precautions during the construction period to avoid re-sedimentation of the pipes and culverts. Any sediment deposited as a result of construction activities shall be removed at the Contractor's expense.

- Bridge No. 2 – Station 0+055, 31 m long, 1150 x 820 mm corrugated steel pipe arch (CSPA) culvert.
- King's Highway No. 401 – 55 m long, 1520 mm span x 1220 mm rise concrete box culvert.

10.0 ACCESS BRIDGE WORK

10.1 Location of New Access Bridges

The new culvert shall be installed as shown on the drawings attached hereto. The centerline of the new culvert shall be located to align itself with the existing laneway.

10.2 Removal of Existing Culverts

The Contractor shall exercise caution when removing these materials as to minimize damage to the drain banks. Any damage to the drain shall be restored to original conditions at the expense of the Contractor. The removed materials (existing culvert debris and end wall materials) shall be hauled away off-site.

10.3 Drainage Pipe Materials

Materials shall be as follows:

Culvert Pipe

Bridge No. 1 – Station 0+010: New 16.0 m long, 1150 x 820 mm aluminized Type II corrugated steel pipe arch (CSPA) wall thickness of 2.0 mm and 68 mm x 13 mm corrugations with rerolled ends.

Bridge No. 3 – Station 0+091: New 12.5 m long, 1150 x 820 mm aluminized Type II corrugated steel pipe arch (CSPA) wall thickness of 2.0 mm and 68 mm x 13 mm corrugations with rerolled ends.

Bridge No. 4 – Station 0+205: New 65 m long, 1150 x 820 mm polymer laminated corrugated steel pipe (CSP), wall thickness of 2.0 mm and 68 mm x 13 mm corrugations with rerolled ends.

New culverts shall be joined with annular aluminized corrugated wide bolt and angle couplers (minimum of 8 corrugation overlap and 2.8 mm wall thickness) and no single

pipe less than 6.0 m in length. All pipes connected with couplers shall abut to each other with no more than a 25 mm gap between pipes prior to installation of the coupler and wrapped with filter fabric.

Pipe Bedding Below Pipe to Pipe Culvert Springline 20-25 mm clear stone conforming to OPSS Division 10.

Backfill Above Pipe Springline up to Bottom of Driveway Surface Materials Granular 'A' made from crushed limestone conforming to OPSS Division 10.

Asphalt Driveway Surface 80 mm thickness HL3 hot mix asphalt surface (two 40 mm lifts)

Erosion Stone All stone to be used for erosion protection shall be 125 - 250 mm clear quarried rock or OPSS 1004, minimum 300 mm thickness.

Buffer Strips Dry native material free of topsoil, organic matter, broken concrete, steel, wood and deleterious substances.

Filter Fabric "Non-Woven" geotextile filter fabric with a minimum strength equal to or greater than Terrafix 270R, Amoco 4546, Mirafi 140NC or approved equivalent.

11.0 ACCESS BRIDGE WORK – FUTURE REPLACEMENT

11.1 Location of New Bridges

The future replacement of Bridge No. 2 shall be constructed in accordance with the specifications and drawings attached hereto. The centerline of the new culvert shall be located to align itself with the existing laneway in each case.

11.2 Removal of Existing Culverts

The Contractor shall exercise caution when removing these materials as to minimize damage to the drain banks. Any damage to the drain shall be restored to original conditions at the expense of the Contractor. The removed materials (existing culvert debris and end wall materials) shall be hauled away off-site.

11.3 Materials for New Bridges

Materials shall be as follows:

<i>Culvert Pipe</i>	Bridge No. 2 – Station 0+055: New 35 m long, 1150 x 820 mm aluminized Type II corrugated steel pipe (CSP), wall thickness of 2.0 mm and 68 mm x 13 mm corrugations with rerolled ends. <i>Note:</i> New CSP culverts shall be joined with annular aluminized corrugated wide bolt and angle couplers (minimum of 8 corrugation overlap and 2.8 mm wall thickness) and no single pipe less than 6.0 m in length. All pipes connected with couplers shall abut to each other with no more than a 25 mm gap between pipes prior to installation of the coupler and wrapped with filter fabric.
<i>Pipe Bedding Below Pipe to Pipe Culvert Springline</i>	20-25 mm clear stone conforming to OPSS Division 10.
<i>Backfill Above Pipe Springline up to Bottom of Driveway Surface Materials</i>	Granular 'A' made from crushed limestone conforming to OPSS Division 10.
<i>Driveway Surface</i>	80 mm HL3 Surface Asphalt (two 40 mm lifts)
<i>Erosion Stone</i>	All stone to be used for erosion protection shall be 125 - 250 mm clear quarried rock or OPSS.Muni 1004, minimum 300 mm thickness.
<i>Buffer Strips</i>	Dry native material free of topsoil, organic matter, broken concrete, steel, wood and deleterious substances.
<i>Filter Fabric</i>	"Non-Woven" geotextile filter fabric with a minimum strength equal to or greater than Terrafix 270R, Amoco 4546, Mirafi 140NC or approved equivalent.

11.4 Culvert Installation

Suitable dykes shall be constructed in the drain so that the installation of the pipe can be accomplished in the dry. The drain bottom shall be cleaned, prepared, shaped and compacted to suit the new culvert configuration, as shown on the drawings. Granular materials shall be compacted to 100% of their maximum dry density; imported clean native materials shall be supplied, placed and compacted to 95% of their maximum dry density.

11.5 Sloping Stone End Walls

End walls shall be constructed of quarry stone rip-rap, as specified herein. Each end wall shall extend from the invert of the new culvert to the top of the proposed lane. The end walls shall be sloped 1 vertical to 1.5 horizontal with a filter fabric underlay surrounding the pipe and spanning across the entire width of the drain and wrapping around the drain banks to align with the ends of the new pipe culvert. The minimum thickness requirement of the erosion stone layer is 300 mm with no portion of the filter fabric to be exposed to sunlight.

11.6 Native Materials

Native materials suitable for use as backfill, as defined under Section 10.3, shall be salvaged from the existing bridge site, as required to complete the work as shown on the drawings, (**Native Backfill Zone only**). Where there is an insufficient amount of native fill materials for backfilling the culvert, the Contractor may elect to import additional dry native materials or alternatively use Granular 'B' at his/her own expense.

11.7 Lateral Tile Drains

Should the Contractor encounter any lateral tiles within the proposed culvert limits not shown on attached drawings, the Contractor shall re-route the outlet tile drain(s) in consultation with the Drainage Superintendent, as required, to accommodate the new culvert. **Tile drain outlets through the wall of the new culvert pipe will not be permitted.** All costs associated with re-routing lateral tile drains (if any) shall be at the Contractor's expense.

Care must be taken in handling plastic drain pipe in cold weather to avoid causing damage.

Plastic drain pipe shall be held in position on planned grade immediately after installation by careful placement of backfill material.

11.8 Asphalt Driveway Restoration

Asphalt driveways shall be constructed as follows:

- 80 mm HL3 Surface Asphalt (two 40 mm lifts)

Asphalt lifts shall be compacted to 98% of the Maximum Standard Marshall Density for hot mix asphalt.

11.9 Site Cleanup and Restoration

As part of the work and upon completion, the Contractor shall remove and dispose of, off-site any loose timber, logs, stumps, large stones, rubber tires, cinder blocks or other debris from the drain bottom and from the side slopes. Where the construction works cross a lawn, the Contractor shall take extreme care to avoid damaging the lawn, shrubs and trees encountered.

Upon completion of the work, the Contractor shall completely restore the area by the placement and fine grading of topsoil and seeding or sodding the area as specified by the Engineer or Drainage Superintendent.

SPECIAL PROVISIONS – TILE DRAIN

11.0 DRAINAGE PIPE CONSTRUCTION

11.1 Setting Out

The Engineer shall provide the Contractor in writing with benchmarks and points of reference. From these benchmarks and points of reference, the contractor will do his own setting out. The setting out by the Contractor shall include but shall not be limited to the preparation of grade sheets, the installation of centerline stakes, grade stakes, offsets, and sight rails.

If, during the setting out, the contractor finds an error in the benchmarks or points of reference provided by the Engineer or is uncertain as to the interpretation of the information provided or the work intended, he shall notify the Engineer immediately for additional verification or clarification before proceeding with construction.

The Contractor shall be responsible for the true and proper setting out of the works and for the correctness of the position, levels, dimensions and alignment of all parts of the work.

The Contractor shall be responsible to ensure that the alignment selected results in a minimum depth of cover of 300 mm over the top of the drainage pipe to be installed.

If, at any time during the progress of the works, an error shall appear or arise in the position, levels, dimensions or alignment of any part of the works, the Contractor shall, at his own expense, rectify such error to the satisfaction of the Engineer, unless such error is based on incorrect data supplied in writing by the Engineer.

11.2 Alignment and Removal of Existing 600 mm diameter HDPE pipe (Bridge No. 4)

Prior to commencing the work, the Contractor is to locate the course of the existing tile and mark it in the field at 30 m intervals before establishing the alignment for the proposed work.

The drainage pipe shall be laid on the alignment as shown on the drawings. The Contractor shall remove the existing 600 mm diameter HDPE pipe as the work progresses upstream.

After the existing tile drain has been removed it shall be disposed of off-site at an approved disposal location.

11.3 Profile

The drainage pipe shall be laid so that its invert shall be at the gradeline shown on the profile, which gradeline is governed by the benchmarks. The profile shows, for the convenience of the Contractors and others, the approximate depth of cut from the surface of the ground at 50 metre intervals, to the final invert of the drainage pipe in metres and decimals of a metre. Benchmarks, which have been established along the course of the drain, shall govern the final elevation of the drain. The locations and elevations of the benchmarks are shown on the General Details.

A variation in grade may be tolerated where the actual capacity of the drain exceeds the required capacity. The as-constructed invert of the drainage pipe shall not deviate from the specified gradeline more than 10% of the internal diameter of the drainage pipe. These deviations are allowable, provided they are gradual over a distance of not less than 10 m. No reverse grade shall be allowed.

11.4 Obstructions

All brush, timber, logs, stumps, stones or other obstructions that interfere with the construction of the drain, encountered along the course of the drain are to be removed by the Contractor. Timber, logs and stumps are to be dealt with in the same manner as specified for brush and trees. Large stones and other similar material are to be piled near the limit of the working corridor and the disposal of this material will be the responsibility of the Contractor.

11.5 Drainage Pipe Materials

11.5.1 Concrete Pipe

Tile Drain New 900 mm (24") diameter reinforced concrete pipe 100-D
(*Sta. 0+249 to Sta. 0+410*) according to A257.2 standards.

Pipe Bedding Cut trench bottom to conform to shape of pipe otherwise
Under Entire Pipe Granular 'A' conforming to OPSS Division 10.

Backfill Granular 'A' conforming to OPSS Division 10.

11.6 Excavating the Trench

Construction of the trench shall normally start at the outlet and proceed upstream and be by excavator. The trench walls may be cut vertically to a height of 1 metre from the trench bottom. Beyond 1 metre of the trench bottom the walls are to be cut to 1:1 side slopes.

Minimum width of trench, measured at the top of the drainage pipe, shall be equal to the outside diameter of the drainage pipe plus approximately half of the outside pipe diameter on both sides of the pipe, to permit proper granular material bedding placement around the drainage pipe.

The bottom of the trench shall be cut to a minimum of 150 mm below the gradeline to allow for the clearstone bedding materials.

Any additional excavated material not required for backfilling purposes shall be disposed of off-site.

The topsoil is to be separated from the subsoil and during the backfilling operation it shall be replaced as the top layer.

11.7 Laying Drainage Pipe

The Contractor shall supply and install clearstone material for bedding, placed to a depth of 150 mm below the design invert of the pipe and shaped to receive the pipe. After pipe placement, Granular 'B' backfill shall be placed and compacted to the springline of the pipe throughout its entire length.

Laying of the drainage pipe shall normally begin at the lower end of the drain and progress upstream.

All soil or debris in the drainage pipe shall be removed before installation.

All drainage pipes shall be free from clinging wet or frozen material that would hinder the laying of the drainage pipe on grade.

Before work is suspended for the day, all drainage pipe laid in trenches shall be blinded and any open ends closed.

Care must be taken in handling plastic drain pipe in cold weather to avoid causing damage.

Plastic drain pipe shall be held in position on planned grade immediately after installation by careful placement of backfill material.

11.8 Connections

Existing lateral drainage pipe encountered during the removal of the existing Demonte Branch Drain tile shall be connected to the new drainage pipe with prefabricated PVC tees.

Existing drains shall be inspected by the Drainage Superintendent and if found to be in working order, they shall be connected to the new system. Drains containing very little sediment shall be directly connected and drains containing substantial quantities of sediment shall be indirectly connected through filter material.

Drains carrying sewage or farmstead wastes shall not be connected to the drainage system.

Plastic tubing connections to rigid drainage pipe shall be made with manufactured plastic adapters.

Directional changes in plastic tubing may be made without the use of fittings provided that the centre line radius of the bend is not less than five times the tubing diameter.

Manufactured "T", "Y", or elbow fittings shall be used for connections at the junction of two drains.

All connections shall be carried out by the Contractor as part of his work. The cost of connections shall be an expense of the drain.

The Contractor shall plug the existing tile in the wall of the trench, on the opposite side on which the connection is made, if the tile extends across the trench. The Contractor shall provide a list each day, showing the number, stations and location of connections which shall be confirmed and verified daily by the Drainage Superintendent in charge of the work. The work shall be carried out to the satisfaction of the Drainage Superintendent.

11.9 Backfilling

After the Drainage Superintendent has inspected the laying of the drainage pipe, granular material compacted to 98% Standard Proctor Density shall be used as backfill material.

Large stones, roots, broken pipe and other material likely to impede or damage field equipment shall be removed from the backfill and disposed of by the Contractor.

To avoid the danger of damaging the drainage pipe, large stones and lumps of frozen earth may not be placed in the trench during the backfill operation.

Where plastic tubing is not blinded in a separate operation, a backfilling method shall be used that permits backfill material to roll into the trench and provide uniform soil placement around tubing, immediately after installation.

Except at laneways and road crossings, granular backfill material shall be compacted to 98% Standard Proctor Density.

12.0 STORM SEWER PIPE DRAIN

OPSS Form 410 shall apply and govern except as extended or amended herein. The size, type and class of sewer pipe shall meet CSA A257.2 standards. For reinforced concrete storm sewers, the bedding shall be Class 'B' as per OPSD 802.03 using approved Granular 'A' materials. The bedding shall be recessed to receive the hubs of the bell and spigot ends in order to allow the barrel of the pipe to be uniformly supported on compacted Granular 'A' bedding material for its entire length.

If the sewer pipe is situated within a traveled driveway or roadway the entire width and depth of the trench shall be backfilled with Granular 'A' material and compacted to 100% standard proctor density. Where the sewer is situated beyond the limits of the roadway, defined as the distance to 1.5 metres from the back of new roadway curb, the remaining excavation above the bedding shall be backfilled with select native material and mechanically compacted to 95% standard proctor density.

The Contractor shall install the pipe using rubber gasket joints and shall be joined in accordance with the manufacturer's instructions using approved gaskets and lubricating materials.

13.0 PRECAST CONCRETE MAINTENANCE HOLES (MH)

OPSS Form 407 and OPSD 701 shall apply and govern except as extended or amended herein. The Contractor shall supply and install precast concrete maintenance holes complete with frames, covers, safety platforms, ladder rungs, adjustment rings. Maintenance holes shall be placed on 300 mm compacted granular 'A' material and shall be backfilled around with approved granular materials in maximum 300 mm lifts to 98% standard proctor density. Where maintenance holes are located under roadways, backfill shall be non-shrink fill materials (Portland cement stabilized granular backfill as per OPSD standards). All maintenance holes shall come equipped with a minimum 600 mm deep sump.

14.0 STONE EROSION PROTECTION (SEP)

The Contractor shall supply and install the required quantities of graded stone rip-rap erosion protection materials where specified. All stone to be used for erosion protection shall be 125 - 250 mm clear **quarried rock** or OPSS 1001 placed over a non-woven filter fabric Terrafix 270R or approved equivalent. **Concrete rip-rap will not be permitted.**

The minimum thickness requirement of the erosion stone layer is 300 mm with no portion of the filter fabric to be exposed.

GENERAL SPECIFICATIONS

1.0 AGREEMENT AND GENERAL CONDITIONS

The part of the Specifications headed "Special Provisions" which is attached hereto forms part of this Specification and is to be read with it. Where there is any difference between the requirements of this General Specification and those of the Special Provisions, the Special Provisions shall govern.

Where the word "Drainage Superintendent" is used in this specification, it shall mean the person or persons appointed by the Council of the Municipality having jurisdiction to superintend the work.

Tenders will be received and contracts awarded only in the form of a lump sum contract for the completion of the whole work or of specified sections thereof. The Tenderer agrees to enter into a formal contract with the Municipality upon acceptance of the tender. The General Conditions of the contract and Form of Agreement shall be those of the Stipulated Price Contract CCDC2-Engineers, 1994 or the most recent revision of this document.

2.0 EXAMINATION OF SITE, PLANS AND SPECIFICATIONS

Each tenderer must visit the site and review the plans and specifications before submitting his/her tender and must satisfy himself/herself as to the extent of the work and local conditions to be met during the construction. Claims made at any time after submission of his/her tender that there was any misunderstanding of the terms and conditions of the contract relating to site conditions, will not be allowed. The Contractor will be at liberty, before bidding to examine any data in the possession of the Municipality or of the Engineer.

The quantities shown or indicated on the drawings or in the report are estimates only and are for the sole purpose of indicating to the tenderers the general magnitude of the work. The tenderer is responsible for checking the quantities for accuracy prior to submitting his/her tender.

3.0 MAINTENANCE PERIOD

The successful Tenderer shall guarantee the work for a period of one (1) year from the date of acceptance thereof from deficiencies that, in the opinion of the Engineer, were caused by faulty workmanship or materials. The successful Tenderer shall, at his/her own expense, make good and repair deficiencies and every part thereof, all to the satisfaction of the Engineer.

Should the successful Tenderer for any cause, fail to do so, then the Municipality may do so and employ such other person or persons as the Engineer may deem proper to make such repairs or do such work, and the whole costs, charges and expense so incurred may be deducted from any amount due to the Tenderer or may be collected otherwise by the Municipality from the Tenderer.

4.0 GENERAL CO-ORDINATION

The Contractor shall be responsible for the coordination between the working forces of other organizations and utility companies in connection with this work. The Contractor shall have no cause of action against the Municipality or the Engineer for delays based on the allegation that the site of the work was not made available to him by the Municipality or the Engineer by reason of the acts, omissions, misfeasance or non-feasance of other organizations or utility companies engaged in other work.

5.0 RESPONSIBILITY FOR DAMAGES TO UTILITIES

The Contractor shall note that overhead and underground utilities such as hydro, gas, telephone and water are not necessarily shown on the drawings. It is the Contractor's responsibility to contact utility companies for information regarding utilities, to exercise the necessary care in construction operations and to take other precautions to safeguard the utilities from damage. All work on or adjacent to any utility, pipeline, railway, etc., is to be carried out in accordance with the requirements of the utility, pipeline, railway, or other, as the case may be, and its specifications for such work are to be followed as if they were part of this specification. The Contractor will be liable for any damage to utilities.

6.0 CONTRACTOR'S LIABILITY

The Contractor, his/her agents and all workmen or persons under his/her control including sub-contractors, shall use due care that no person or property is injured and that no rights are infringed in the prosecution of the work. The Contractor shall be solely responsible for all damages, by whomsoever claimable, in respect to any injury to persons or property of whatever description and in respect of any infringement of any right, privilege or easement whatever, occasioned in the carrying on of the work, or by any neglect on the Contractor's part.

The Contractor, shall indemnify and hold harmless the Municipality and the Engineer, their agents and employees from and against claims, demands, losses, costs, damages, actions, suits, or proceedings arising out of or attributable to the Contractor's performance of the contract.

7.0 PROPERTY BARS AND SURVEY MONUMENTS

The Contractor shall be responsible for marking and protecting all property bars and survey monuments during construction. All missing, disturbed or damaged property bars and survey monuments shall be replaced at the Contractor's expense, by an Ontario Land Surveyor.

8.0 MAINTENANCE OF FLOW

The Contractor shall, at his/her own cost and expense, permanently provide for and maintain the flow of all drains, ditches and water courses that may be encountered during the progress of the work.

9.0 ONTARIO PROVINCIAL STANDARDS

Ontario Provincial Standard Specifications (OPSS) and Ontario Provincial Standard Drawings (OPSD) shall apply and govern at all times unless otherwise amended or extended in these Specifications or on the Drawing. Access to the electronic version of the Ontario Provincial Standards is available online through the MTO website, free of charge to all users. To access the electronic standards on the Web go to <http://www.mto.gov.on.ca/english/transrd/>. Under the title Technical Manuals is a link to the Ontario Provincial Standards. Users require Adobe Acrobat to view all pdf files.

10.0 APPROVALS, PERMITS AND NOTICES

The construction of the works and all operations connected therewith are subject to the approval, inspection, by-laws and regulations of all Municipal, Provincial, Federal and other authorities having jurisdiction in respect to any matters embraced in this Contract. The Contractor shall obtain all approvals and permits and notify the affected authorities when carrying out work in the vicinity of any public utility, power, underground cables, railways, etc.

11.0 SUBLETTING

The Contractor shall keep the work under his/her personal control, and shall not assign, transfer, or sublet any portion without first obtaining the written consent of the Municipality.

12.0 TIME OF COMPLETION

The Contractor shall complete all work on or before the date fixed at the time of tendering. The Contractor will be held liable for any damages or expenses occasioned by his/her failure to complete the work on time and for any expenses of inspection, superintending, re-tendering or re-surveying, due to their neglect or failure to carry out the work in a timely manner.

13.0 TRAFFIC CONTROL

The Contractor will be required to control vehicular and pedestrian traffic along roads at all times and shall, at his/her own expense, provide for placing and maintaining such barricades, signs, flags, lights and flag persons as may be required to ensure public safety. The Contractor will be solely responsible for controlling traffic and shall appoint a representative to maintain the signs and warning lights at night, on weekends and holidays and at all other times that work is not in progress. All traffic control during construction shall be strictly in accordance with the **Occupational Health and Safety Act** and the current version of the **Ontario Traffic Manuals**. Access to the electronic version of the **Ontario Traffic Manual** is available online through the MTO website, free of charge to all users. To access the electronic standards on the Web go to <http://www.mto.gov.on.ca/english/transrd/>, click on "Library Catalogue," under the "Title," enter "Ontario Traffic Manual" as the search. Open the applicable "Manual(s)" by choosing the "Access Key," once open look for the "Attachment," click the pdf file. Users require Adobe Acrobat to view all pdf files.

Contractors are reminded of the requirements of the Occupational Health and Safety Act pertaining to Traffic Protection Plans for workers and Traffic Control Plan for Public Safety.

14.0 SITE CLEANUP AND RESTORATION

As part of the work and upon completion, the Contractor shall remove and dispose of, off-site any loose timber, logs, stumps, large stones, rubber tires, cinder blocks or other debris from the drain bottom and from the side slopes. Where the construction works cross a lawn, the Contractor shall take extreme care to avoid damaging the lawn, shrubs and trees encountered. Upon completion of the work, the Contractor shall completely restore the area by the placement and fine grading of topsoil and seeding or sodding the area as specified by the Engineer or Drainage Superintendent.

15.0 UTILITY RELOCATION WORKS

In accordance with Section 26 of the Drainage Act, if utilities are encountered during the installation of the drainage works that conflict with the placement of the new culvert, the operating utility company shall relocate the utility at their own costs. The Contractor however will be responsible to co-ordinate these required relocations (if any) and their co-ordination work shall be considered incidental to the drainage works.

16.0 FINAL INSPECTION

All work shall be carried out to the satisfaction of the Drainage Superintendent for the Municipality, in compliance with the specifications, drawings and the Drainage Act. Upon completion of the project, the work will be inspected by the Engineer and the Drainage Superintendent.

Any deficiencies noted during the final inspection shall be immediately rectified by the Contractor.

Final inspection will be made by the Engineer within 20 days after the Drainage Superintendent has received notice in writing from the Contractor that the work is completed, or as soon thereafter as weather conditions permit.

17.0 FISHERIES CONCERNS

Standard practices to be followed to minimize disruption to fish habitat include embedment of the culvert a minimum 10% below grade, constructing the work 'in the dry' and cutting only trees necessary to do the work (no clear-cutting). No in-water work is to occur during the timing window unless otherwise approved by the appropriate authorities.

Aug 06, 2022 - 2:39pm C:\pwworking\director\projects to 2017\339p\40501433\175617-03-DRN-CON (Aug 5 2022).dwg

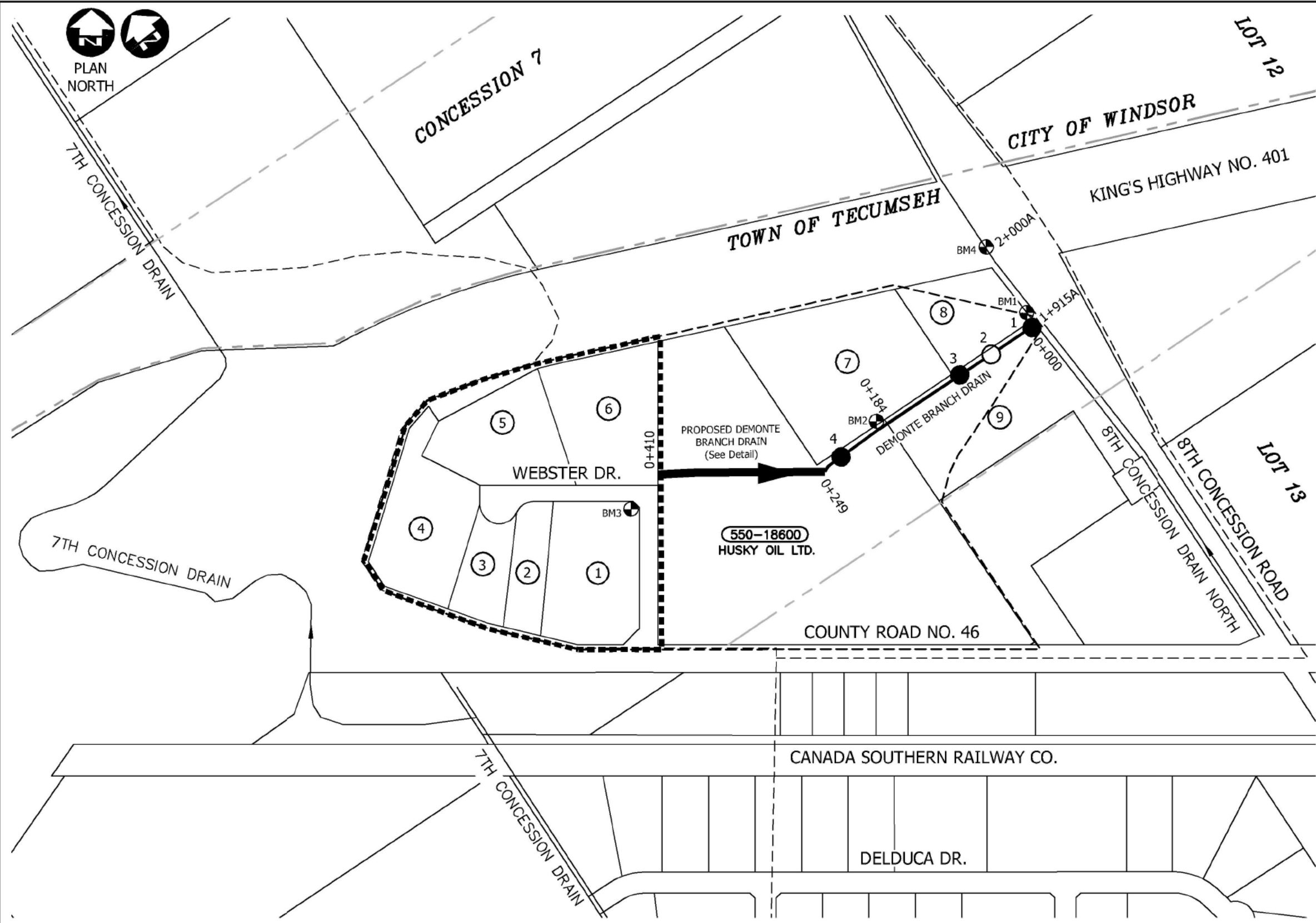

PARCEL OWNERSHIP		
NO.	ROLL NO.	OWNER
1	550-18615	BENSAV REAL ESTATE INC.
2	550-18614	1871418 ONTARIO INC.
3	550-18612	BENSAV REAL ESTATE INC.
4	550-18610	MINISTRY OF TRANSPORTATION
5	550-02601	TOROMONT INDUSTRIES LTD.
6	550-18602	BARNIM PROPERTY HOLDINGS INC.
7	550-17900	R.J. CYR CO INC.
8	550-17800	LAVAL TOOL & MOULD LTD
9	550-18000	679637 ONTARIO LTD.

SITE BENCHMARKS	
BM1-	TOP OF FIRE HYDRANT ON WEST SIDE OF 8TH CONCESSION DRAIN NORTH AT STATION 0+004. ELEVATION=189.90m
BM2-	TOP OF FIRE HYDRANT AT END OF OPEN PORTION OF EX. DEMONTE BRANCH DRAIN ON EAST SIDE OF DRIVEWAY TO R.J. CYR CO. STATION 0+189. ELEVATION=190.39m
BM3-	TOP OF FIRE HYDRANT ON SOUTHWEST SIDE OF BEND IN WEBSTER DRIVE. ELEVATION=190.73m
BM4-	TOP OF SOUTH END OF CONCRETE BOX CULVERT UNDER KING'S HWY. NO. 401 STATION 2+000 OF THE 8TH CONCESSION DRAIN NORTH. ELEVATION=189.58m

NOTE: CONTRACTOR TO VERIFY BENCHMARKS PRIOR TO CONSTRUCTION.

LEGEND	
	AREA REQUIRING DRAINAGE
	SURROUNDING DRAINS SUBWATERSHEDS
	DEMONTE BRANCH DRAIN
	OTHER DRAINS
	BRIDGE REPLACEMENT
	EXISTING BRIDGE
	BENCHMARK

WATERSHED PLAN
SCALE=1:4,000



Conditions of Use
Verify elevations and/or dimensions on drawing prior to use. Report any discrepancies to Dillon Consulting Limited.
Do not scale dimensions from drawing.
Do not modify drawing, re-use it, or use it for purposes other than those intended at the time of its preparation without prior written permission from Dillon Consulting Limited.

No.	ISSUED FOR	DATE	BY
4	FINAL REPORT SUBMISSION	AUG. 5/22	MDH
3	ERCA REVIEW	JULY 22/22	MDH
2	PUBLIC INFORMATION CENTRE REVIEW	FEB. 18/22	MDH
1	CLIENT REVIEW	OCT. 21/21	MDH

DESIGN	MDH	REVIEWED BY	CDP
DRAWN	WLB	CHECKED BY	TRO
DATE	August 5, 2022		
SCALE	AS SHOWN		

PROJECT NO. 17-5617
DRAWING SCALES BASED ON A 11" X 17" SHEET

'SCHEDULE G'	
Drainage Report for the	
DEMONTE BRANCH DRAIN	
Town of Tecumseh	
SHEET TITLE	WATERSHED PLAN
PAGE NO.	1 of 5

Aug 06, 2022 - 2:41pm C:\pwworking\directory\projects to 2017\33\p\40501433\75617-03-DRN-CON (Aug 5 2022).dwg

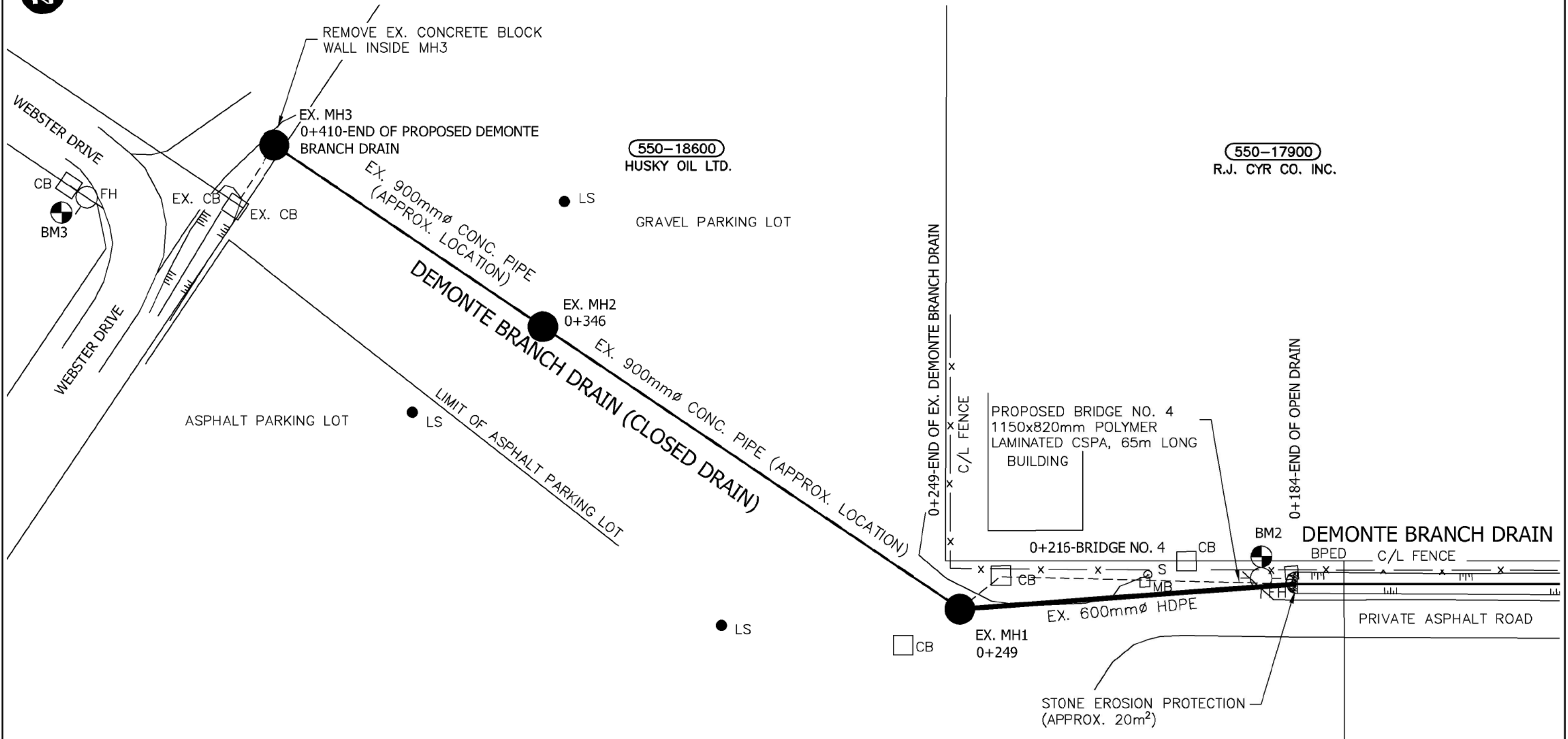

DETAIL PLAN
SCALE=1:750



Conditions of Use
Verify elevations and/or dimensions on drawing prior to use. Report any discrepancies to Dillon Consulting Limited.
Do not scale dimensions from drawing.
Do not modify drawing, re-use it, or use it for purposes other than those intended at the time of its preparation without prior written permission from Dillon Consulting Limited.

No.	ISSUED FOR	DATE	BY
4	FINAL REPORT SUBMISSION	AUG. 5/22	MDH
3	ERCA REVIEW	JULY 22/22	MDH
2	PUBLIC INFORMATION CENTRE REVIEW	FEB. 18/22	MDH
1	CLIENT REVIEW	OCT. 21/21	MDH

DESIGN	MDH	REVIEWED BY	CDP
DRAWN	WLB	CHECKED BY	TRO
DATE	August 5, 2022		
SCALE	AS SHOWN		

PROJECT NO. 17-5617
DRAWING SCALES BASED ON A 11" X 17" SHEET

'SCHEDULE G'	
Drainage Report for the DEMONTE BRANCH DRAIN	
Town of Tecumseh	
SHEET TITLE	DETAIL PLAN
PAGE NO.	2 of 5

Aug 06, 2022 - 2:46pm C:\pwworking\projects\2017\330\175617-03-DRN-CON (Aug 5 2022).dwg

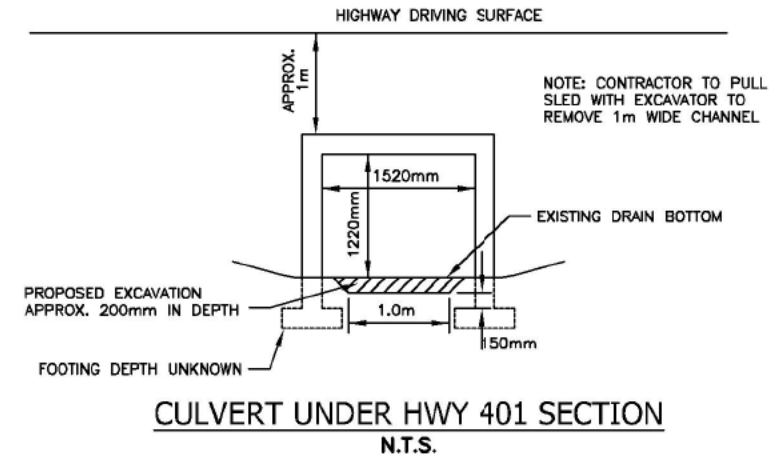
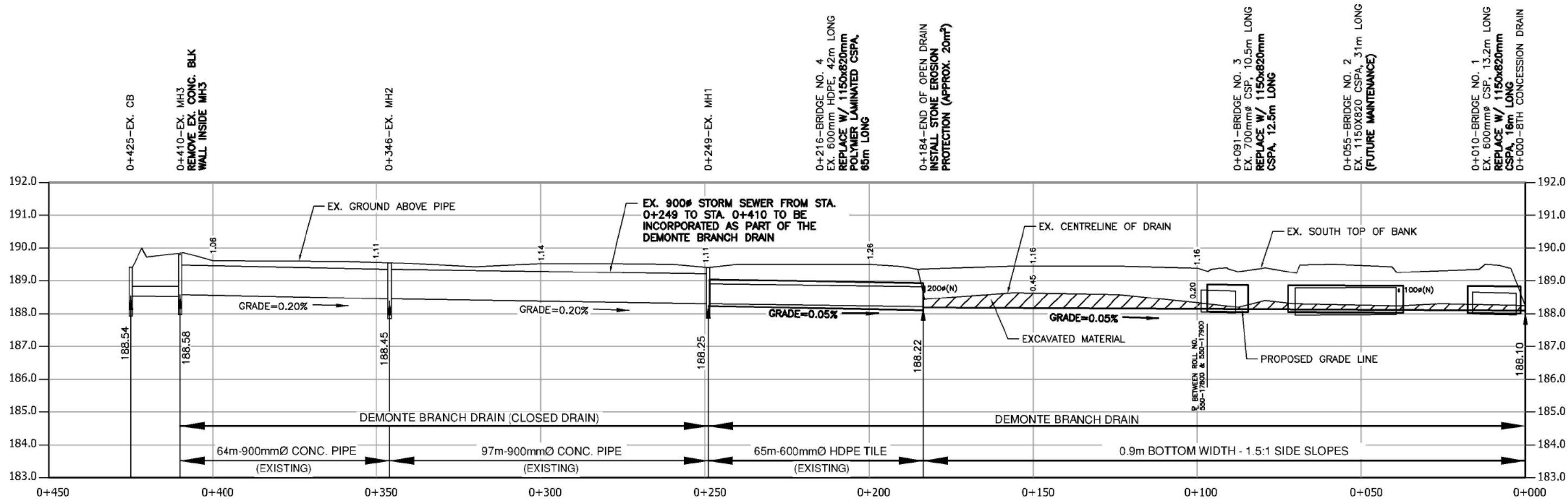

8TH CONCESSION DRAIN NORTH PROFILE
 SCALE-HORIZ.=1:1250
 VERT. =1:100

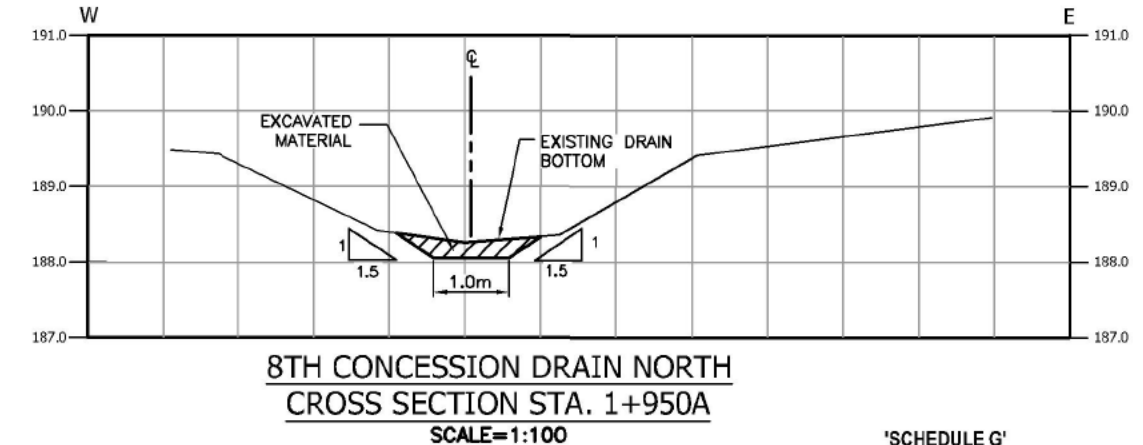
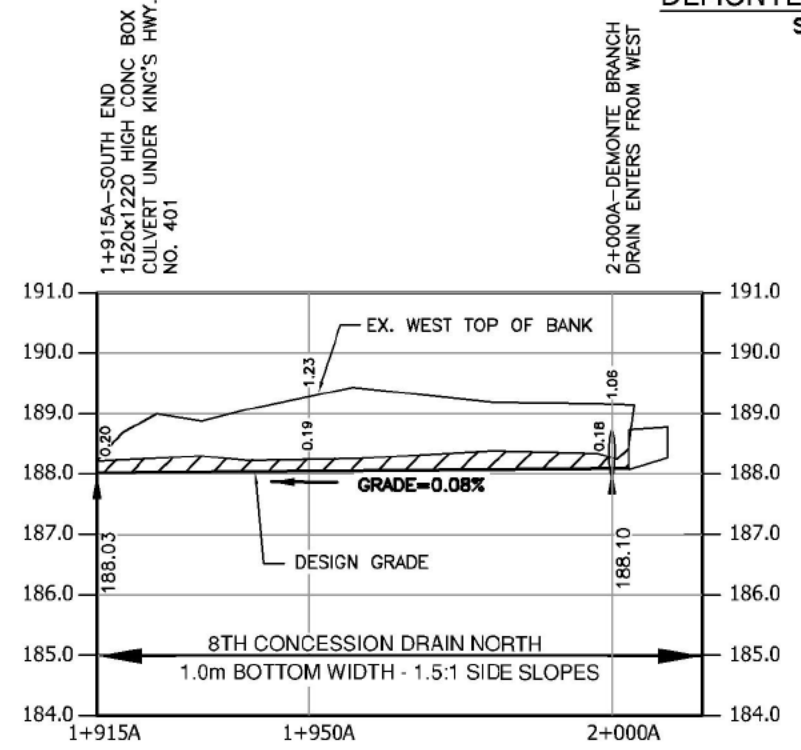

Conditions of Use

Verify elevations and/or dimensions on drawing prior to use. Report any discrepancies to Dillon Consulting Limited.

Do not scale dimensions from drawing.

Do not modify drawing, re-use it, or use it for purposes other than those intended at the time of its preparation without prior written permission from Dillon Consulting Limited.

No.	ISSUED FOR	DATE	BY
4	FINAL REPORT SUBMISSION	AUG. 5/22	MDH
3	ERCA REVIEW	JULY 22/22	MDH
2	PUBLIC INFORMATION CENTRE REVIEW	FEB. 18/22	MDH
1	CLIENT REVIEW	OCT. 21/21	MDH

DESIGN	MDH	REVIEWED BY	CDP
DRAWN	WLB	CHECKED BY	TRO
DATE	August 5, 2022		
SCALE	AS SHOWN		

DILLON CONSULTING

PROJECT NO. 17-5617

DRAWING SCALES BASED ON A 11" X 17" SHEET

'SCHEDULE G'

Drainage Report for the
DEMONTE BRANCH DRAIN EXTENSION
 Town of Tecumseh

SHEET TITLE	PROFILE
PAGE NO.	3 of 5

Aug 06, 2022 - 2:51pm C:\pwworking\projects\2017\33\p\40501433\75617-03-DRN-CON (Aug 5 2022).dwg

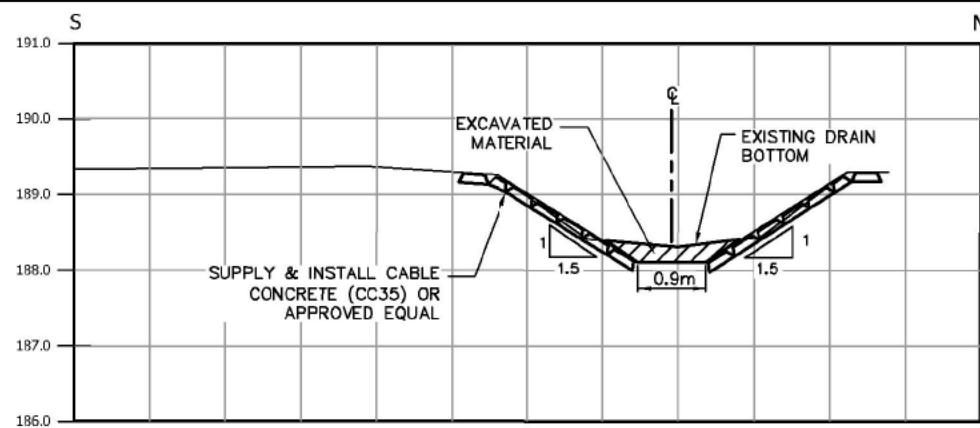

CROSS SECTION STA. 0+025
SCALE=1:100

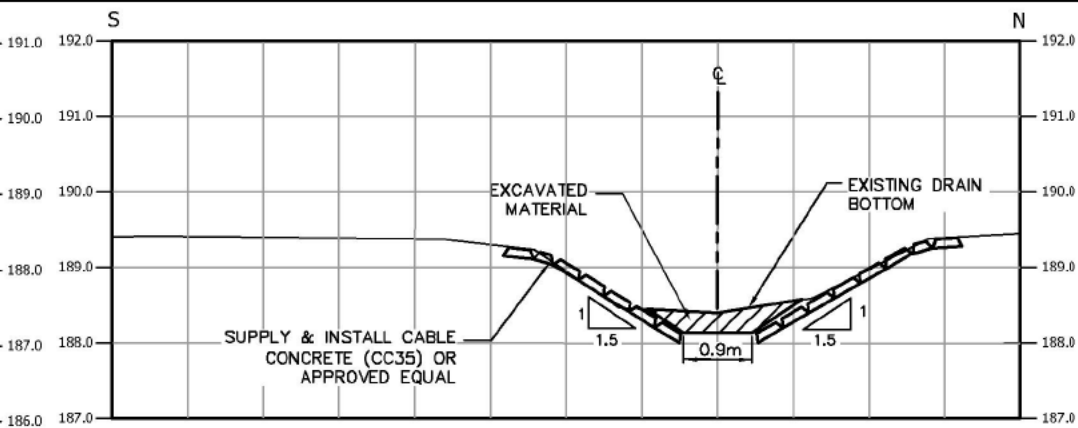

CROSS SECTION STA. 0+080
SCALE=1:100

NOTE: CABLE CONCRETE TO BE DESIGNED BY CONTRACTOR. DRAWINGS TO BE SEALED BY A LICENSED PROFESSIONAL ENGINEER IN THE PROVINCE OF ONTARIO.

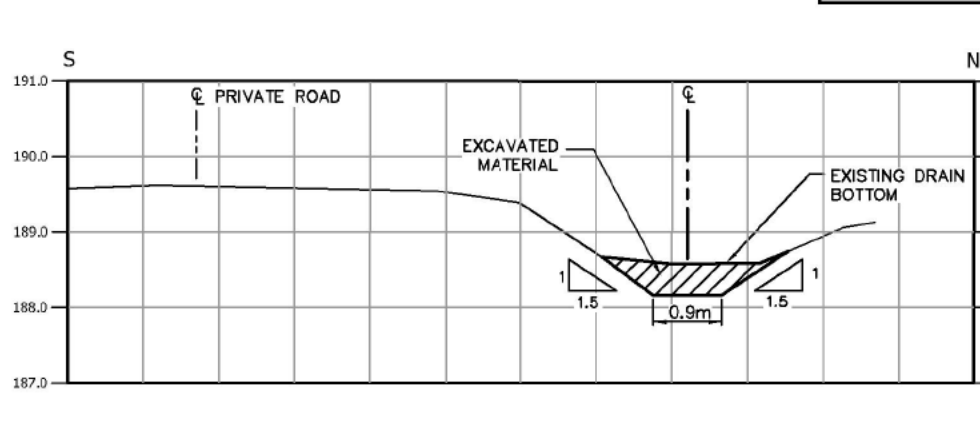

CROSS SECTION STA. 0+124
SCALE=1:100

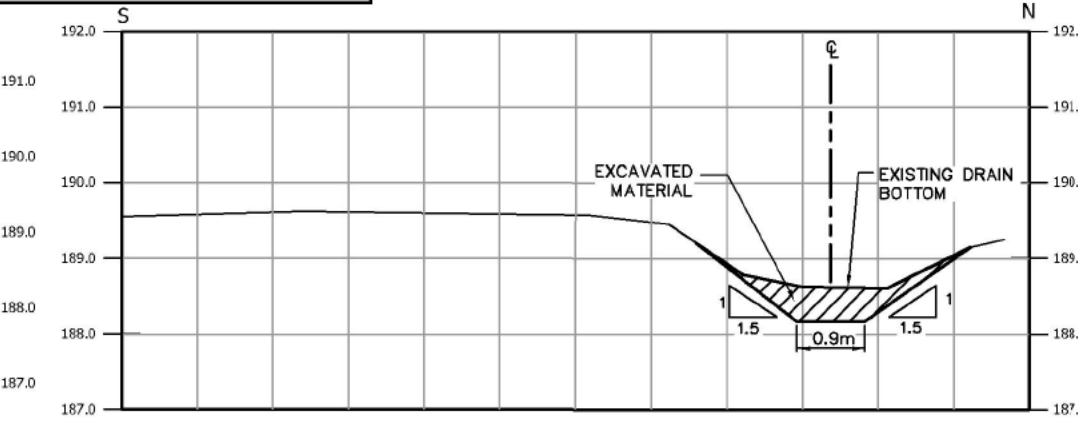

CROSS SECTION STA. 0+155
SCALE=1:100

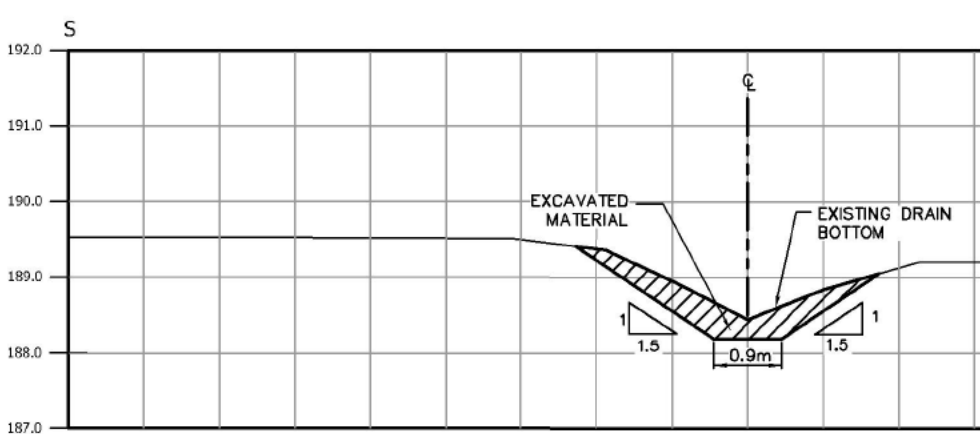

CROSS SECTION STA. 0+183
SCALE=1:100

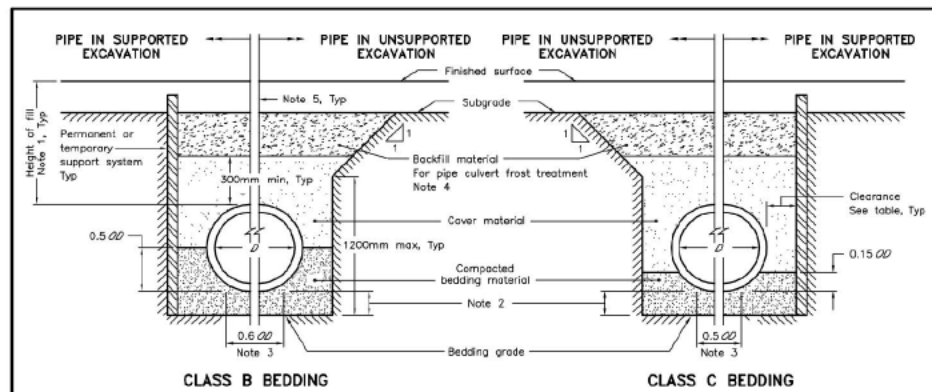

NOTES:
 1 Height of fill is measured from the finished surface to top of pipe.
 2 The minimum bedding depth below the pipe shall be 0.15D in no case shall this dimension be less than 150mm or greater than 300mm.
 3 The pipe bed shall be compacted and shaped to receive the bottom of the pipe.
 4 Pipe culvert frost treatment shall be according to OPSD 803.030 and 803.031.
 5 Condition of excavation is symmetrical about centreline of pipe.
 A Soil types as defined in the Occupational Health and Safety Act and Regulations for Construction Projects.
 B All dimensions are in metres unless otherwise shown.

LEGEND:
 D - Inside diameter
 OD - Outside diameter

CLEARANCE TABLE		
Pipe Inside Diameter (mm)	Clearance (mm)	
900 or less	300	
Over 900	500	

ONTARIO PROVINCIAL STANDARD DRAWING
 RIGID PIPE BEDDING, COVER, AND BACKFILL
 TYPE 1 OR 2 SOIL - EARTH EXCAVATION
 Nov 2015 Rev 3
 OPSD 802.030

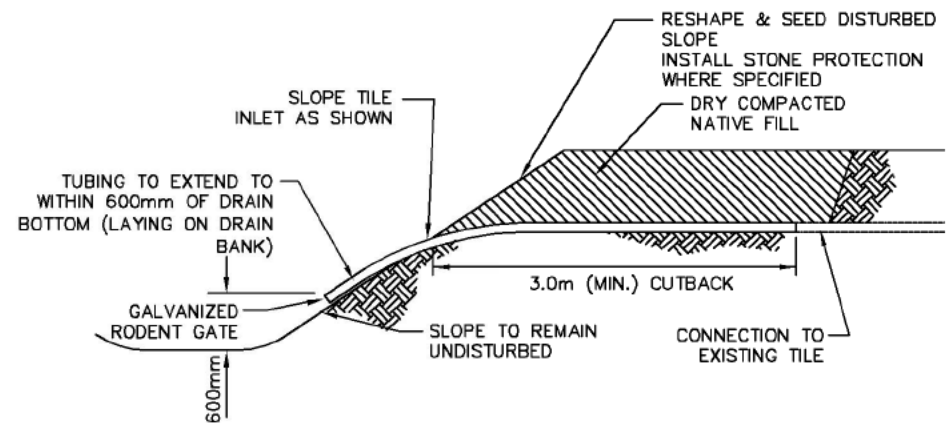

TYPICAL DRAINAGE TUBING TILE INLET REPLACEMENT DETAIL
(FOR TILES 150mmØ OR SMALLER)
NOT TO SCALE

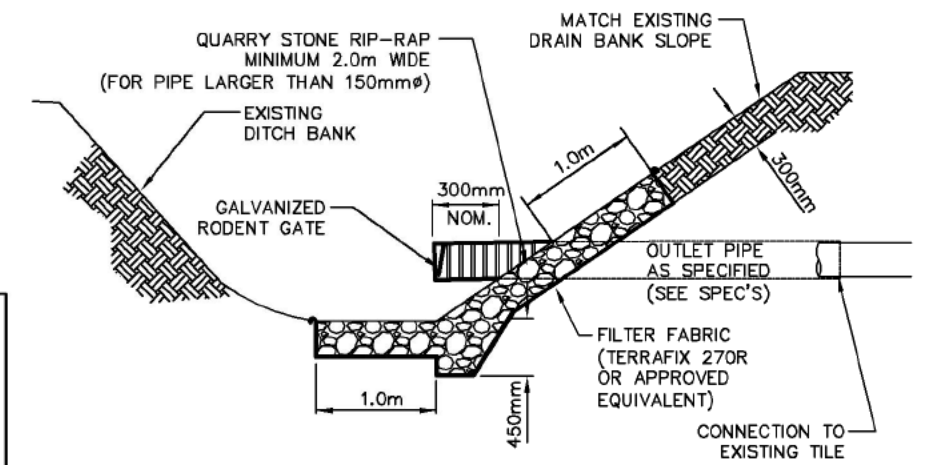

TYPICAL CSP TILE INLET REPLACEMENT DETAIL
NOT TO SCALE



Conditions of Use
 Verify elevations and/or dimensions on drawing prior to use. Report any discrepancies to Dillon Consulting Limited.
 Do not scale dimensions from drawing.
 Do not modify drawing, re-use it, or use it for purposes other than those intended at the time of its preparation without prior written permission from Dillon Consulting Limited.

No.	ISSUED FOR	DATE	BY
4	FINAL REPORT SUBMISSION	AUG. 5/22	MDH
3	ERCA REVIEW	JULY 22/22	MDH
2	PUBLIC INFORMATION CENTRE REVIEW	FEB. 18/22	MDH
1	CLIENT REVIEW	OCT. 21/21	MDH

DESIGN	REVIEWED BY
MDH	CDP
DRAWN	CHECKED BY
WLB	TRO
DATE	August 5, 2022
SCALE	AS SHOWN

PROJECT NO. 17-5617
 DRAWING SCALES BASED ON A 11" X 17" SHEET

'SCHEDULE G'
 Drainage Report for the
DEMONTE BRANCH DRAIN
 Town of Tecumseh
 SHEET TITLE **CROSS SECTIONS & DETAILS**
 PAGE NO. **4 of 5**

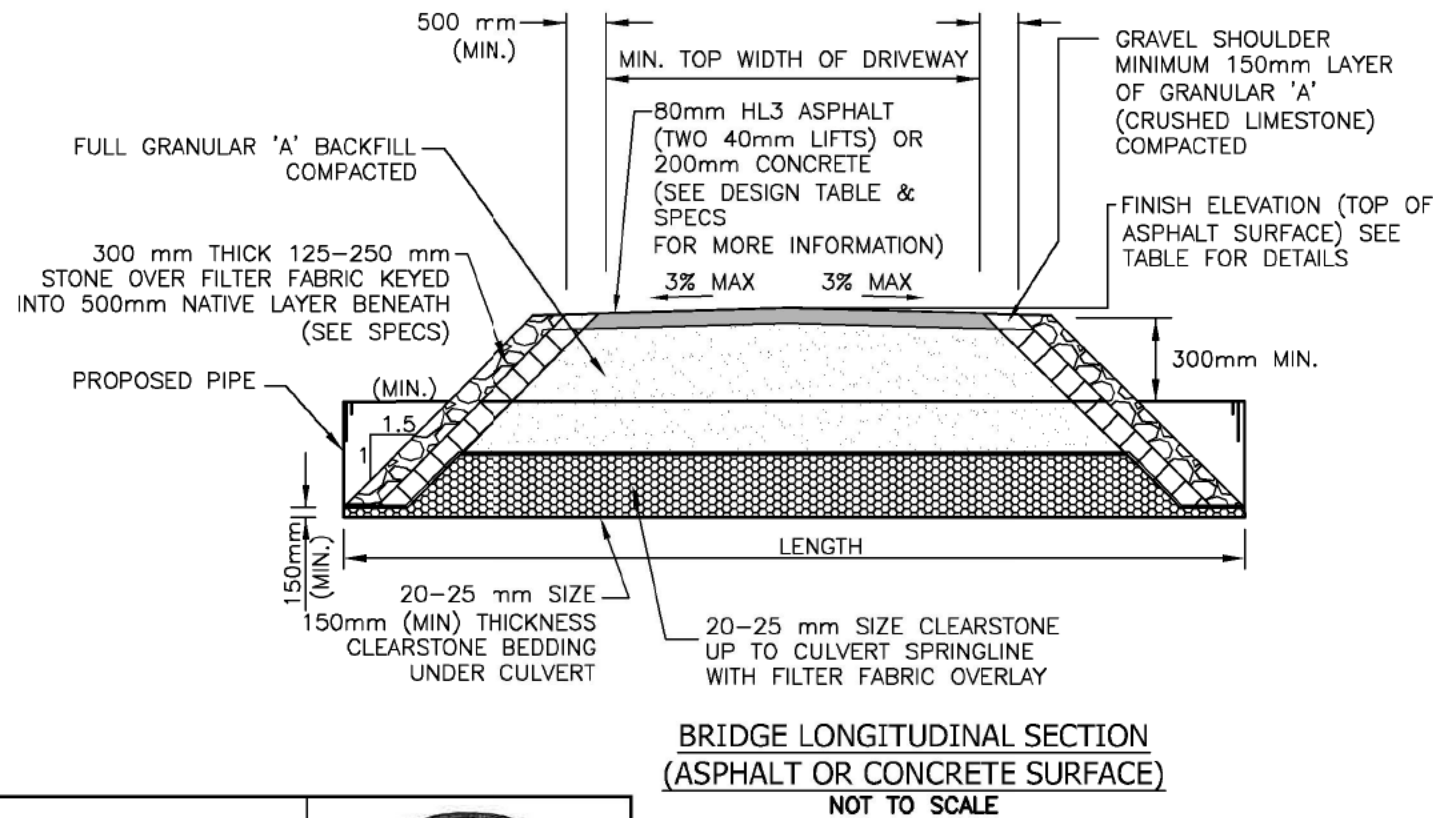
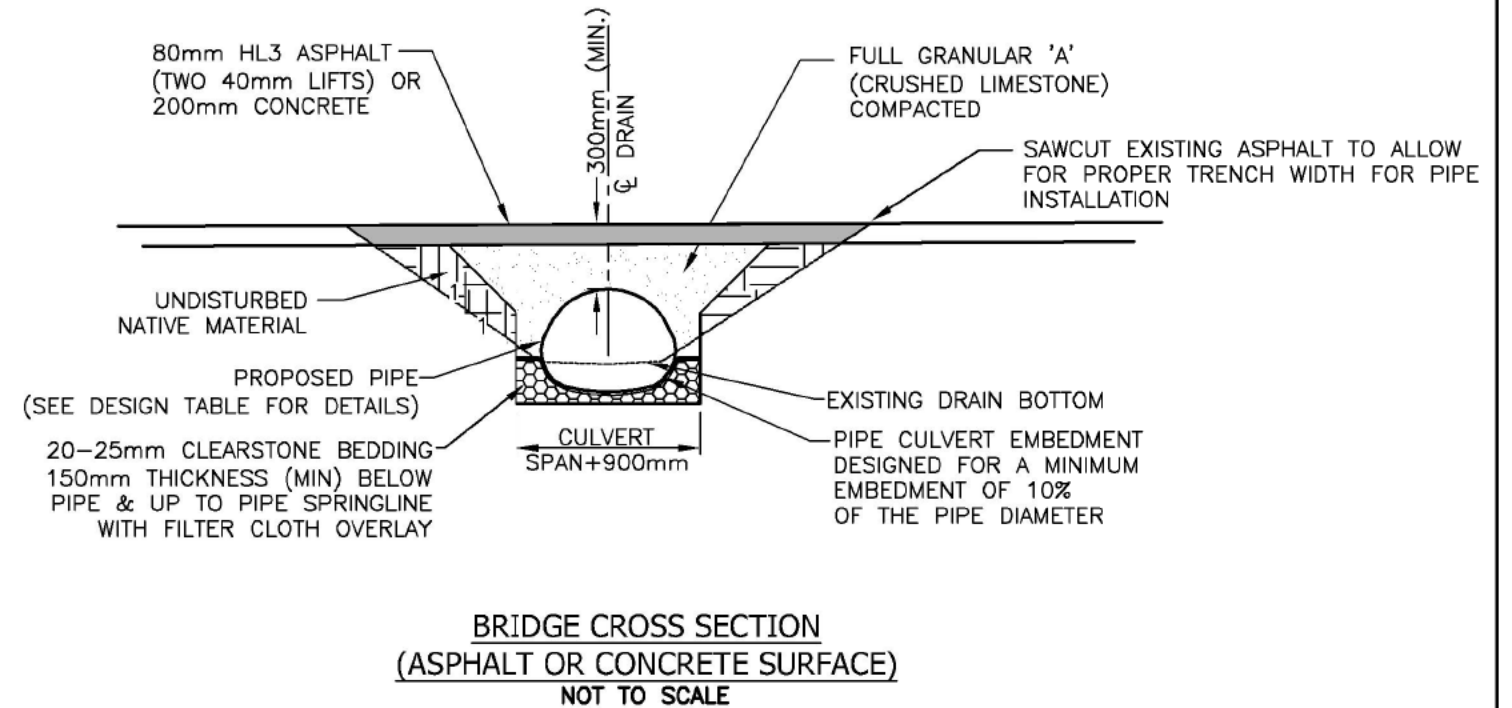
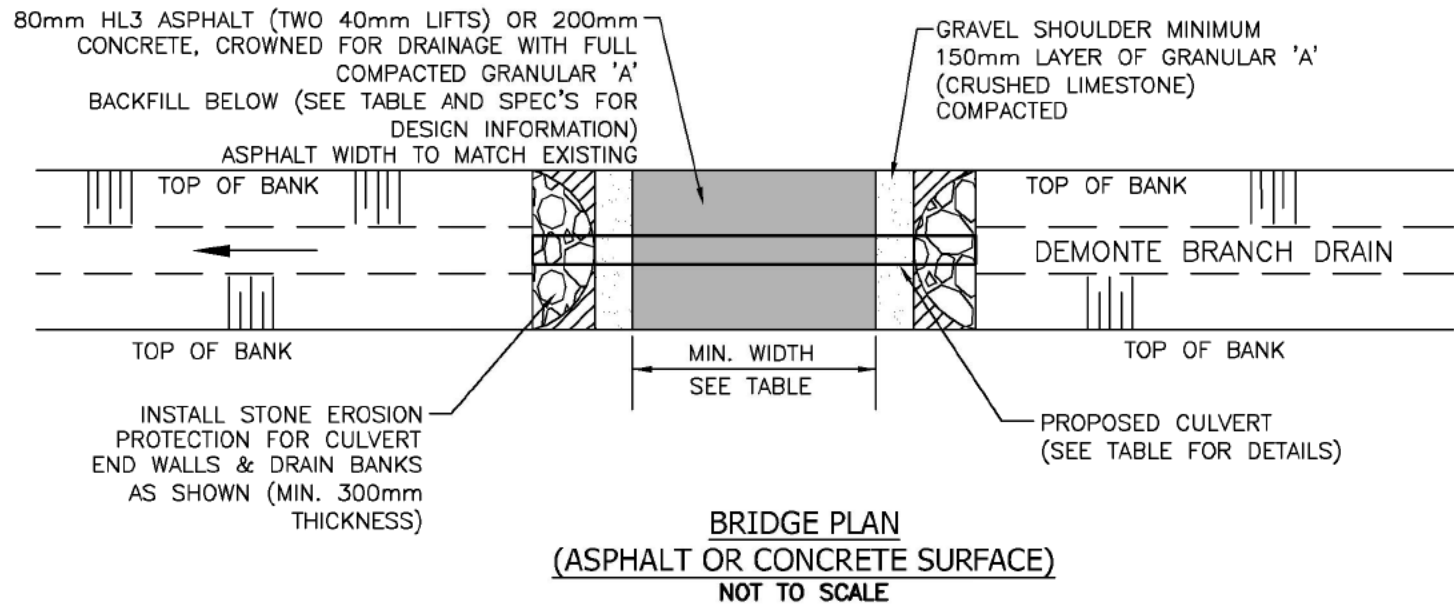

DESCRIPTION	BRIDGE No. 1	BRIDGE No. 2 (FUTURE)	BRIDGE No. 3	BRIDGE No. 4
BRIDGE LOCATION (STA.)	0+010	0+055	0+091	0+216
PIPE INVERT ELEV. U/S SIDE(m)	188.03	188.06	188.07	188.17
PIPE INVERT ELEV. D/S SIDE(m)	188.01	188.02	188.05	188.14
TOP OF ϕ DRIVEWAY SURFACE ELEV. (m)	189.47	189.50	189.38	189.50
DRAIN BOTTOM (m) (DESIGN) (AT CENTRELINE OF CULVERT)	188.10	188.12	188.14	188.24
MIN. TOP WIDTH OF DRIVEWAY (m)	7.3	28.0	6.1	30
MIN. CULVERT GRADE (%)	0.10%	0.10%	0.10%	0.05%
CULVERT TYPE	CSPA	CSPA	CSPA	CSPA
CULVERT MATERIAL	ALUM.	ALUM.	ALUM.	POLYMER LAM.
CULVERT LENGTH (m)	16.0	35.0	12.5	65.0
CULVERT THICKNESS (mm)	2.0	2.0	2.0	2.0
CULVERT CORRUGATIONS (mm)	68x13	68x13	68x13	68x13
PIPE SIZE (mm)	1150x820	1150x820	1150x820	1150x820
CULVERT ENDWALL TYPE	SLOPING	SLOPING	SLOPING	SLOPING

Aug 06, 2022 - 2:52pm C:\pwworking\projects\2017\330\40501433\175617-03-DRN-CON (Aug 5 2022).dwg



Conditions of Use

Verify elevations and/or dimensions on drawing prior to use. Report any discrepancies to Dillon Consulting Limited.
Do not scale dimensions from drawing.
Do not modify drawing, re-use it, or use it for purposes other than those intended at the time of its preparation without prior written permission from Dillon Consulting Limited.

No.	ISSUED FOR	DATE	BY
4	FINAL REPORT SUBMISSION	AUG. 5/22	MDH
3	ERCA REVIEW	JULY 22/22	MDH
2	PUBLIC INFORMATION CENTRE REVIEW	FEB. 18/22	MDH
1	CLIENT REVIEW	OCT. 21/21	MDH

DESIGN	REVIEWED BY
MDH	CDP
DRAWN	CHECKED BY
WLB	TRO
DATE	August 5, 2022
SCALE	AS SHOWN

PROJECT NO. 17-5617
DRAWING SCALES BASED ON A 11" X 17" SHEET

'SCHEDULE G'
Drainage Report for the
DEMONTE BRANCH DRAIN
Town of Tecumseh
SHEET TITLE **BRIDGE DETAILS**
PAGE NO. **5 of 5**